

HEALTH AND PHYSICAL EDUCATION

STUDENT TEXTBOOK GRADE 9

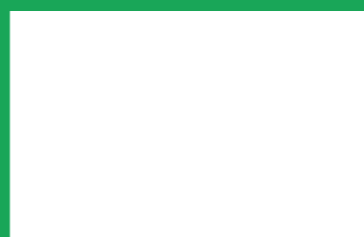

ISBN XXXXXXXXXXXX



FEDERAL DEMOCRATIC REPUBLIC OF ETHIOPIA
MINISTRY OF EDUCATION

Price ETB 167.00

HEALTH AND PHYSICAL EDUCATION STUDENT TEXTBOOK GRADE 9



FDRE
MOE



HEALTH AND PHYSICAL EDUCATION

STUDENT TEXTBOOK GRADE 9



FEDERAL DEMOCRATIC REPUBLIC OF ETHIOPIA
MINISTRY OF EDUCATION

Take Good Care of This Textbook



This textbook is the property of your school
Take good care not to damage or lose
Here are 10 ideas to help take care of the book:

1. Cover the book with protective material, such as plastic, old newspapers or magazines.
2. Always keep the book in a clean dry place.
3. Be sure your hands are clean when you use the book.
4. Do not write on the cover or inside pages.
5. Use a piece of paper or cardboard as a bookmark.
6. Never tear or cut out any pictures or pages.
7. Repair any torn pages with paste or tape.
8. Pack the book carefully when you place it in your school bag.
9. Handle the book with care when passing it to another person
10. When using a new book for the first time, lay it on its back. Open only a few pages at a time. Press lightly along the bound edge as you turn the pages. This will keep the cover in good condition.



HEALTH AND PHYSICAL EDUCATION

STUDENT TEXTBOOK

GRADE 9

Writers:

Sisay Mengistu (phD)
Bizuneh Yirga (phD)

Editors:

Tesfaye Dessalegn (phD) (Content editor)
Solomon Wolde (Msc) (Pedagogical content editor)
Teshome Egere (phD) (Language editor)

Illustrator:

Haileyesus Gedefaw (phD)

Designer:

Demissie Gashu (phD)

Evaluators :

Markos yohannes (phD)
Habtamu Demelash (phD)



FEDERAL DEMOCRATIC REPUBLIC OF ETHIOPIA
MINISTRY OF EDUCATION



HAWASSA UNIVERSITY

First Published xxxxx 2022 by the Federal Democratic Republic of Ethiopia, Ministry of Education, under the General Education Quality Improvement Program for Equity (GEQIP-E) supported by the World Bank, UK's Department for International Development/DFID-now merged with the Foreign, Common wealth and Development Office/FCDO, Finland Ministry for Foreign Affairs, the Royal Norwegian Embassy, United Nations Children's Fund/UNICEF), the Global Partnership for Education (GPE), and Danish Ministry of Foreign Affairs, through a Multi Donor Trust Fund.

© 2022 by the Federal Democratic Republic of Ethiopia, Ministry of Education. All rights reserved. The moral rights of the author have been asserted. No part of this textbook reproduced, copied in a retrieval system or transmitted in any form or by any means including electronic, mechanical, magnetic, photocopying, recording or otherwise, without the prior written permission of the Ministry of Education or licensing in accordance with the Federal Democratic Republic of Ethiopia as expressed in the Federal Negarit Gazeta, Proclamation No. 410/2004 - Copyright and Neighboring Rights Protection.

The Ministry of Education wishes to thank the many individuals, groups and other bodies involved – directly or indirectly – in publishing this Textbook. Special thanks are due to Hawassa University for their huge contribution in the development of this textbook in collaboration with Addis Ababa University, Bahir Dar University and Jimma University. Copyrighted materials used by permission of their owners. If you are the owner of copyrighted material not cited or improperly cited, please contact the Ministry of Education, Head Office, Arat Kilo, (P.O.Box 1367), Addis Ababa Ethiopia.

PHOTO CREDIT:

<https://www.pngegg.com>
<http://clipart-library.com>
<https://www.stock.adobe.com>
<https://www.pngegg.com>
<https://www.123rf.com>
<http://clipart-library.com>
[http:// opening.downloadspring-2021.html](http://opening.downloadspring-2021.html)
<https://www.wallsheaven.com>

Printed by:

xxxxxxx PRINTING

P.O.Box xxxxxx

xxxxxxx, ETHIOPIA

Under Ministry of Education Contract no. xxxxxxxxxxxx

ISBN: xxxxxxxxxxxx

Foreword

Education and development are closely related endeavors. This is the main reason why it is said that education is the key instrument in Ethiopia's development and social transformation. The fast and globalized world we now live in requires new knowledge, skill and attitude on the part of each individual. It is with this objective in view that the curriculum, which is not only the Blueprint but also a reflection of a country's education system, must be responsive to changing conditions.

It has been almost three decades since Ethiopia launched and implemented new Education and Training Policy. Since the 1994 Education and Training Policy our country has recorded remarkable progress in terms of access, equity and relevance. Vigorous efforts also have been made, and continue to be made, to improve the quality of education.

To continue this progress, the Ministry of Education has developed a new General Education Curriculum Framework in 2021. The Framework covers all pre-primary, primary, Middle level and secondary level grades and subjects. It aims to reinforce the basic tenets and principles outlined in the Education and Training Policy, and provides guidance on the preparation of all subsequent curriculum materials – including this Teacher Guide and the Student Textbook that come with it – to be based on active-learning methods and a competency-based approach.

In the development of this new curriculum, recommendations of the education Road Map studies conducted in 2018 are used as milestones. The new curriculum materials balance the content with students' age, incorporate indigenous knowledge where necessary, use technology for learning and teaching, integrate vocational contents, incorporate the moral education as a subject and incorporate career and technical education as a subject in order to accommodate the diverse needs of learners.

Publication of a new framework, textbooks and teacher guides are by no means the sole solution to improving the quality of education in any country. Continued improvement calls for the efforts of all stakeholders. The teacher's role must become more flexible ranging from lecturer to motivator, guider and facilitator. To assist this, teachers have been given, and will continue to receive, training on the strategies suggested in the Framework and in this teacher guide.

Teachers are urged to read this Guide carefully and to support their students by putting into action the strategies and activities suggested in it.

For systemic reform and continuous improvement in the quality of curriculum materials, the Ministry of Education welcomes comments and suggestions which will enable us to undertake further review and refinement.

ACKNOWLEDGEMENT

We wish to express our appreciations to those who played a vital role in development of this Physical Education Textbook. It would not have been successful without active participation of different stakeholders in the area of education. First, our thanks go to the Health and Physical Education teaching and learning material preparation team who devoted their time day and night for the successful completion of the documents. We extend our special thanks to all reviewers and validators who critically reviewed the documents and gave us constructive comments and suggestions for the betterment of the documents. In addition, our gratitude goes to individuals who came from different parts of the country to attend the validation workshop and gave us constructive comments. Finally, we also would like to thank Ministry of Education, particularly Curriculum Development and Implementation Directorate Office, Centre of Excellences, particularly Hawassa University that allowed us to work with their professionals in the development of this textbook.

PREFACE

Health and Physical Education (HPE) is an education given through physical as well as mental engagement in activities to develop all aspects of personality. In health and physical education, students will learn the skills needed to be successful in life as active, healthy, and socially responsible citizens. The health and physical education curriculum promotes important educational values and goals that support the development of character. Physical Education (PE) develops students' competence and confidence to take part in a range of physical activities that become a central part of their lives, both in and out of school. This book is written to provide the fundamental skills in HPE for grade 9 students of Federal Democratic Republic of Ethiopia. It is expected that the knowledge and skills gained through this book topics in health and physical education which offer physical and mental engagements of activities helps students acquiring the required skills.

The key features of this book will help the students to:

- understand how sport and society are interrelated;
- recognize the participation level of male and female in sports;
- understand the impact of drug use in health;
- understand the basic principles of physical fitness training;
- plan the exercise program designing based on principles of training;
- understand the role of physical exercise on hypokinetic diseases;
- understand the long-term and short term effects of exercise on cardiovascular, respiratory, flexibility and muscular systems;
- develop positive attitude to perform physical fitness exercise and,
- develop the fundamental techniques of track and field events, football, volleyball, basketball, handball and self-defense.

The text has been designed in a simple and friendly way. This text focuses on the fundamental skills of HPE, which change slowly through long-life activities. This not only makes the information remain useful to a student to graduate but also makes the student focus on the concepts of health and physical education. This book also illustrates the latest developments in the rapidly changing world of physical activities of physical education. Review questions have also been given at the end of each unit.

TABLE OF CONTENTS

ACKNOWLEDGEMENT	I
PREFACE	II
UNIT ONE	1
SPORT AND SOCIETY	1
1.1. Sport and economy	1
1.2. Sport and gender	4
1.3. Sport and technology	7
1.4. Consequence of doping	9
Unit summary	11
Unit review questions	12
UNIT TWO	12
HEALTH AND PHYSICAL FITNESS	14
2.1. Body system and exercise	14
2.2. Hypokinetic diseases and exercise	17
2.3. Principles of physical fitness training	18
2.4. Exercise which develops cardiovascular endurance	20
2.5. Exercise which develops muscular endurance and strength	22
2.6. Exercise which develops flexibility	25
Unit summary	28
Unit review questions	28
UNIT THREE	30
ATHLETICS	30
3.1 History of athletics	31
3.1.1 Brief history of Athletics in Ethiopia	31
3.1.2. Brief history of Athletics in Africa	32
3.2. Sprint and sprnt relay	32
3.2.1 Basic sprint techniques	32
3.2.2. Basic relay techniques	35
Unit summary	37
Unit review questions	38
UNIT FOUR	40
FOOTBALL	40
4.1 Brief history of football	40
4.1.1. World history of football	40
4.1.2 African football history	43
4.1.3 Ethiopian football history	34
4.2. Rules of Football	47
4.2.1. The playing area	47
4.2.2. The players	48
4.2.3. The referee	49
4.2.4. Duration of the game	50

4.2.5. Ball in and ball out	50
4.2.6. Scoring	50
4.2.7. Off-side	50
4.2.8. Throw-in	51
4.2.9. Corner kick	51
4.3. Skills of Football	52
4.3.1. Chest control	52
4.3.2. Heading	53
Unit Summary	56
Unit review questions	56
UNIT FIVE	58
VOLLEYBALL	58
5.1 A brief history of volleyball	58
5.1.1 Historical development of volleyball in the World	58
5.1.2. Historical development of volleyball in African	59
5.1.3. Historical development of volleyball in Ethiopia	60
5.2. Rules of volleyball	60
5.2.1. Facilities and equipments	60
5.2.2. Participants	62
5.2.3. Playing format	63
5.2.4. Playing action	64
5.3. Spike skill of volleyball	64
5.3.1 Improving volleyball spiking skills	64
5.3.2 Volleyball techniques for spiking	65
5.3.3 Spike in volleyball	65
5.3.3.1 Standing spike	67
5.3.3.2 Off-speed spike	67
5.3.3.3 Hard driven spike	67
5.4.3 Mini game using spike	67
5.4.4 Modified game related to volleyball	69
Unit summary	69
Unit review question	70
UNIT SIX	72
BASKETBALL	72
6.1. The brief history of basketball	72
6.1.1 The history of basketball in the world	72
6.1.2. The history of basketball in African	73
6.1.3. The history of basketball in Ethiopian	74
6.2. Rules of basketball	75
6.2.1. The playing area	75
6.2.2. Equipment	66
6.2.3. Playing regulations	67
6.2.4. Violations and fouls	67

6.3. Under hand lay-up shoot skill of basketbal	79
6.3.1. Under hand lay-up shoot	80
6.3.2. Modified game related to basketball	82
Unit summary	83
Unit review questions	83
UNIT SEVEN	85
HANDBALL	85
7.1 A brief history of handball	85
7.1.1 A brief history of handball in the World	85
7.1.2. A brief history of handball in Africa	87
7.1.3. A brief history of handball in Ethiopia	87
7.2. Rules of handball	88
7.2.1. Playing court	89
7.2.2. Playing time	90
7.2.3. The ball	90
7.2.4. The team	80
7.2.5. Fouls	92
7.3. Basic skill of handball	93
7.3.1. Goolkepping	93
7.3.2. Goolkeeper posture and footwork	94
7.3.3. Goalkeeper's play	96
7.4 Modified game related to handball	97
Unit summary	99
Unit review questions	100
UNIT EIGHT	101
SELF-DEFENSE AND SPORT ETHICS	101
8.1. Essence and roles of self-defense	101
8.2. Principles and rules of self-defense	103
8.3 Basic self-defense techniques	106
8.3.1. Basic stance	106
8.3.2. Escape	107
8.3.3. Strikes	108
8.3.4 Grappling	110
Unit summary	111
Unit review questions	112

UNIT ONE

SPORT AND SOCIETY



Introduction

Health and physical education is one part of general education which enables learner to achieve all rounded personality. In health and physical education, there are a lot of sub-disciplinary field of studies that play a vital role for the learners overall development. One of these disciplines is sport sociology. Sports sociology is the study of the relationship between sports and society. In your grade eight lesson we hope that you have identified the influence of cultural values on sports and vice versa. In this grade, you will identify the relation sport has with notions such as economy, gender and technology. Moreover, the consequence of doping on athletics will be discussed.

Unit objectives

At the end of this unit, you will be able to:

- ☞ understand the the relation sport has with economy, gender and technology;
- ☞ analyse the grave consequences of drug abuse on sport and in life and,
- ☞ influence others on the effect of drug abuse.

Unit Contents

1.1. Sport and economy

1.2. Sport and gender

1.3. Sport and technology

1.4. Consequence of doping

Unit summary

Review questions

KEY WORDS:

Sport, Society,

Economy, Gender,

Technology and

Doping

1.1. Sport and economy

Specific objectives

At the end of this lesson, you will be able to:

- ☞ list at least three local and foreign athletes who invest huge amount of
- ☞ money for development of a country and
- ☞ identify the contribution of sport for economic development.

Start-up activity 1.1.1

1. What do you know about sport? Can you explain your ideas to the class?
2. What do you understand about sport and economy?
3. Explain your idea to the class.

As you have learnt in your elementary Health and Physical Education classes, you have defined sport as “an organized competitive form of play”

You have also seen the fact that sports

activities have enormous benefits for human beings. In this section we will have a look at the relationship between sport and economy.

To begin with the definition of economy, it refers to an area of the production, distribution and trade, as well as consumption of goods and services by different concern here is the contribution of Sports like football, are considered as critical region of financial action which supporting work through makes different agents. Therefore, dear students, our sport for our economic development.

Sports like football, are considered as critical region of financial action which supporting work through makes different work and trade openings for coaches and teachers, wear writers and commentators, venders of sports merchandise and gear, etc.

Moreover, it has extraordinary implication on the world economy due to the nature of its near affiliation with divisions counting instruction, real-estate and tourism. Hence, these days, sports are positioned among the top standard exercises within the economy.

Students, you can see the experience of world class Athletes from Ethiopia and abroad who invest a huge amount of money and contribute for the economic development of the country.

Students, look at the pictures below that depict Ethiopian athletes. They are known not only in the field of athletic but also economy. For example,

Haile Gebresilassie, invested on Hotel Industry (Haile Resorts), Agriculture, and Manufacturing (Car) and others,



Figure 1.1
Athlete Haile Gebresilassie

Derartu Tullu, invested on hotel industry and others.



Figure 1.2
Athlete Derartu Tullu

Kenenisa Bekele invested on hotel industry and others,



Figure 1.3
Athlete Kenenisa Bekele

Tirunesh Dibaba, invested on Hotel Industry and others,

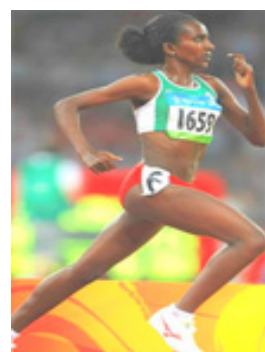

Figure 1.4
Athlete Tirunesh Dibaba

The following are also some professional sportsmen and sportswomen;

Cristiano Ronaldo; invested on CR7 Hotel, Clothing and Perfume Company, Fitness Center, etc.



Figure 1.5
Cristiano Ronaldo

Naomi Osaka became Sweetgreen's youngest ever investor in May, 2021. A long-time customer of the healthy fast-food brand, the 24-year-old revealed she was "proud" of the partnership.



Figure 1.6
Naomi Osaka

Samuel Eto'o; invested on Commercial Company, Betoo Betting Platform.



Figure 1.7
Samuel Eto'o

Didier Drogba, invested on Phoenix Rising, Said Bank, Drogba Foundation.



Figure 1.8
Didier Drogba

After you see the economic advantage of distinctive organization within the sports division you can also subsequently see a number of monetary and nonfinancial elements.

The current (2014 EC) monthly salaries of Ethiopian premier league football players have increased from time to time. It is the leading salary that we have in the sport sector. Being sportsmen and sportswomen, participants can have a possibility to get huge amount of salary. These will bring the economic development of the players that will also have the indirect economic development of the society.

On the other hand, when the country organizes any international sporting event, it directly or indirectly involves the use of partners in the society. Thus, sport industry helps the economic wheel move forward.

Case study 1

Organizing event

The 41st Council for East and Central Africa Football Associations (CEC AFA) Cup was organized by Ethiopia from July, 18-31, 2021 in Bahir Dar. Eleven teams were participated on this competition. All the teams were stayed in Ethiopia for weeks. One team is expected to have an average of 25 members. In addition to the participant

teams, there were some individuals who had a role in organizing this competition and some high level officials and international guests also stayed in Ethiopia. A total of around 400 foreigners took part from opening to clothing ceremony.

Activity ?

Students, form a group and read the above case study and discuss who benefits from this competition? And how they are going to be benefited?

Activity 1.1.2 ?

1. Does sport has contribution for economic benefit of the society? How?
2. Read sport newspapers and books related to sport and economic development and then tell to the class how sports bring about economic development of the society.

All sport events require the following services, and the participants of the sport event will spend lots of money to get these services; like hotel rooms, car rentals, food and beverage, flights in and out of the country, uniforms, equipment and sport products, and advertising, printing and others.

Thus, these sport and sport related events are contributing for the socio economic wheel of the country that leads overall economic development.

Activity 1.1.3 ?

1. Name three world class athletes who contribute for the country economic development.
2. Can you discuss how sport participation contributes for economic development of any country?
3. Consult your family related to sport and economy. Then, reflect your idea to the class.

1.2. Sport and gender

Specific objectives

At the end of this lesson, you will be able to:

- ☞ describe the participation level of male and female in sports and,
- ☞ identify gender equality in sport performance.

Start-up Activity 1. 2.1 ?

1. Do you know the status of female and male in sport participation?
2. Can you tell the relationship between female, male and sport participation?
3. Mention some top level female athletes?

Gender alludes to the social construction of men and women. It bargains with issues such as certain behaviors to men and other to female and strengthens female and male behaviors.

Sport can be a reagent for numerous positive sentiments, feelings, results, and intelligence in one's life. Taking part in sport can also offer assistance for one to create positive individual characteristics such as stress management, communication skills, and the capacity to work well with others. In any case, for positive results to happen, one must have an opportunity to play. Girls and women have not continuously had the same openings and got to sport as boys and men.

In spite of the well-documented benefits of physical movement, various campaigns supporting the appropriation of a healthy way of life and the perpetual stream of encouragement on how to develop dynamic and healthy, significant rate

of the population – more girls and women than boys and men – lead inactive life.



Figure 1.9 Women in sport

The Women's history of sport involvement has tallied a long periods. This participation has illustrated by division and separation but moreover one possessed with major achievements by female competitors and critical advances for gender uniformity and thus the strengthening of women and young girls.



Figure 1.10 Londoner Violet Piercy (the first woman to run a marathon -1928)

The following are among the many remarkable achieves made by females.

Helene Madison

Helene Madison of the United States of America is the first woman to swim the 100-yard freestyle in one minute in the 1932 Olympics;

Maria-Teresa de Filippis

Maria-Teresa de Filippis of Italy is the first woman to compete in a European Grand Prix auto race in 1958;

Nawal El Moutawakel

Grade 9

Nawal El Moutawakel of Morocco is the first woman from Arabian countries to win an Olympic medal for the 400-metre hurdles at the 1984 Olympics;

Tegla Loroupe

Tegla Loroupe of Kenya is a one who in 1994 became the first African woman to win a major marathon;

Fatuma Roba

Fatuma Roba of Ethiopian is also the one who won and became the first Ethiopian women Athlete to win Marathon;

Derartu Tulu

Derartu Tulu of Ethiopia is the one who won and became the first Women Athlete to win 10,000M;

Lidiya Tafesse

Lidiya Tafesse is the one who became the first female international football



Figure 1.11 Lidiya Tafesse

Loza Abera

Loza Abera is the one who became the first professional Ethiopian female footballer.



Figure 1.12 Loza Abera

Tigist Gezahagn

Tigist Gezahagn is the first ever gold medalist for Ethiopia in the history of the Paralympics in the women's T13 1500m event.



Figure 1.12 Athlete Tigist Gezahagn

The T13 category is for athletes with a moderate visual impairment. Athletes in this category have a variety of visual impairments, but can typically recognize contours from a distance of 2 to 6 metres. Athletes in this category do not typically require a guide.

Women have taken up best authority positions like men's in sport, such as Derartu Tulu, Presidents of Ethiopian Athletic Federation.

Furthermore, numerous females, whether they are competitors or not, have to chased work openings in through areas of sport, such as coaches, directors, authorities, fitness center instructors, and sport writers. These progresses were made within the confrontation of various deterrents which have their base on gender orientation.



Figure 1.13 Kathrine Switzer (woman first appearance at Boston marathon)

The next picture illustrated that the USA female athlete, Kathrine Switzer, was finishing the Boston Marathon despite an attempt to eject her from participation.

Activity 1.2.2

Students, discuss in pair and name some women's and their sport participation.

The United Nations Human Rights and Sport for Development and Peace Framework document reveals the right of women's participation in physical education as follows:

“The practice of physical education and sport is a fundamental right for all.”

UNESCO International Charter of Physical Education and Sport, article 1

Likewise, the Federal Constitution recognizes women's rights: Article 35 sub-articles 1, states the rights of women: Women shall, in the enjoyment of rights and protections provided for by this Constitution, have equal right with men.

In addition, sport and physical activity were first specifically recognized as a human right in the International Charter of Physical Education and Sport, adopted in 1978 by the United Nations Educational, Scientific and Cultural Organization (UNESCO).

The Charter states:

“One of the essential conditions for the effective exercise of human rights is that everyone should be free to develop and preserve his or her physical, intellectual, and moral powers, and that access to physical education and sport should consequently be assured and guaranteed for all human beings”.

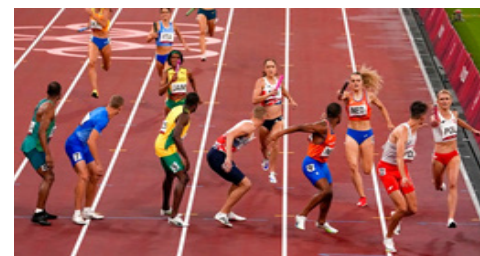

Figure 1.14 Mixed relay-shows gender equal participation in sport

The relationship between gender correspondence and sport isn't exclusively almost accomplishing balance in women's participation and treatment inside sports, but it is additionally almost advancing “sport for gender equality”, or saddling the potential of sport for social strengthening of females and girls. Sport offers an important channel to reinforce women's and girls' capabilities and give data on critical social issues, such as wellbeing, HIV/AIDS and women's rights.

Activity 1.2.3

1. What is the current participation level of females and males in sporting events?
2. Can you mention some sport events which involves both male and female during competition?
3. Students, please go to sport clubs and ask them the level of female sport participation. Then, come with the result and reflect to the whole class.

1.3. Sport and technology

Specific objectives

At the end of this lesson, you will be able to:

- ☞ sort out the impact of technology on sport development and,
- ☞ mention some technological advancement in sport.

Start-up Activity 1.3.1

1. What relationship do you think has sport with technology?
2. Does technology improve sport equipment's and performance? How? Discuss in your group and reflect your result to the class.

Innovation has been started in sport for a long times in a few forms and play crucial part in various sport exercises particularly for the elite sport. Verifiably, innovation plays a vital portion in cutting edge sport, especially in football and athletics to progress the execution of a person. Sport world nowadays is getting innovative by connecting common athletic ability with progressed analytics. And it shrewdly becomes artificial to bring the most note worthy conceivable results on the playing field of sports.

Subsequently, sport and innovation have had solid relationship for a long time. Parts of innovative progressions are connected totally in different sports for the improvement of competitor execution. Without a doubt, the major improvements in fast-growing tech have made a tremendous result on the industry of sport and wellness centres. Along with presently common wellness trackers and versatile apps for distinctive sports exercises, we see modern innovation in sports being confirmed and actualized with tall intrigued. For example; innovative wearable can be mentioned.

These days, the outcome of mechanical improvement in sport is profoundly expanded. These wearables are set to adjust both beginner and proficient sports. Just like the past Fit bit groups

and fundamental pedometers, now a days, diverse wearable items are accessible for the headway of the individual as well as the sport itself. The followings are a few wearable's like wellness observes, shrewd clothing for sports, wellness and well ness like T-shirts, caps, pants, socks and shoes (Sensor-enabled shoes) for football players and runners of track speed, constrain, movement, footing, etc.

eSports

It is a competitive gaming medium that changes gamers. This is the result of a digital technology which emerges in the new market industry. eSports, which incorporates eRacing, fighting games, shooters, etc. is a fast-growing sector built around mobile and PC gaming.

Technology in Sports Equipment

The advancement of technology in sports equipment is very important for producing immersing products like performance tracking systems.

The progression of innovation in sports equipment is exceptionally vital for creating immersing items like performance tracking systems. The choice of arbitrator, umpire, or judges will decide the results of that amusement. Tragically, in numerous sports, off-base choice may be happen. These off-base choices will make struggle between the players and the official. In numerous sports, arbitrator choice, whether the choice is off-base or not, is the final choice. Subsequently, there's no room to adjust or correct that choice.

Now a days, mechanical progressed gadgets which are exceptionally

imperative to distinguish the off-base choice made by the referee and rectified with in a fraction of seconds. Such mechanical progressed devices are executed to help the officials and to create the improvement of the sport that's well known within the world.

Activity 1.3.2

Students, be in pair and discuss on the benefit of technology on sport development.

In Athletics Sports the numbers telling the time taken to wrap up the race translate specifically into a positioning framework. These sports got to have innovative progressed gadgets such as stopwatches and photo-finishes in arrange to settle an accurate and coordinate translation. In the case of football, there's a video assisted referee (VAR). VAR utilized in three fundamental events and one authoritative issue have been recognized as game-changing. These are; goals, penalty decision, and mistaken identity.

Goal line technology

The role of the VAR is to bolster the official to work out whether there was an encroachment meaning an objective ought not to be granted. As the ball has passed the line, play is hindered. Hence there's no coordinate impact on the game.



Figure 1.15 VAR Technology

Penalty decisions

The role of the VAR is to confirm that no clearly wrong decisions are made in conjunction with the award or non-award of a penalty kick



Figure 1.16 VAR Penalty Decision

Direct red card incidents

The role of the VAR is to make sure that no clearly wrong decisions are made in conjunction with sending off or not sending off a player.

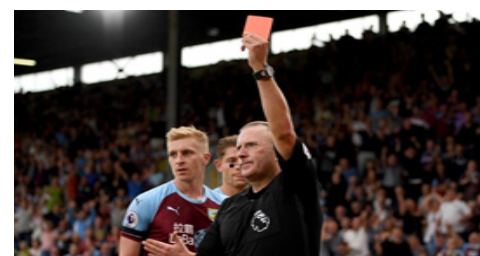

Figure 1.17 Referee's Red Card Decision

Mistaken identity

The referee cautions or sends off the mistaken player, or is hesitant which player should be sanctioned. The VAR will inform the referee so that the correct player can be disciplined.

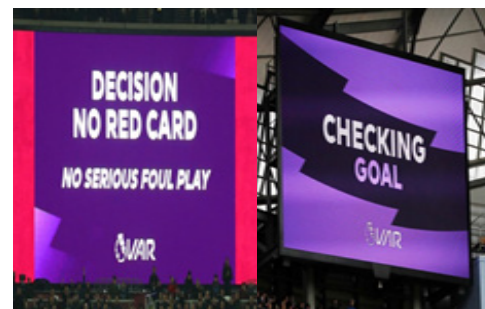

Figure 1.18 VAR Decision Displays

Activity 1.3.4

1. What is the role of technology in the development of sport?
2. List out some technological advancement of sport.
3. Observe one sport competition in TV or in stadium. Then, name those technological advanced equipment with their importance.

1.4. Consequence of doping

Specific objectives

At the end of this lesson, you will be able to;

- ☞ explain how doping defame sport celebrities;
- ☞ reason out why athletes should not use performance enhancing drugs and,
- ☞ associate the impact of drug use with health.

Start-up Activity 1.4.1

1. What do you know about the doping?
2. Can you mention some consequence of doping?

Doping is regularly considered to be the deliberate or inadvertent utilize by athlete.s of drugs or procedures which will enhance performance.

It is the utilization of any stimulant not regularly utilized to expand the impact of activity in athletic challenge over the normal. Any individual intentionally acting or supporting as clarified over might be avoided from anyplace where these rules are in constrain or, in case he may be a competitor, be suspended for a time or something else from assist support in that don competition.

It was known that the larger parts of competitors are clean and abide by

the anti-doping rules. Students, you wish to work difficult to help ensure your status and wearing victories. It is apparent that a few competitors will select to deceive - and we all ought to work difficult to recognize doping conduct and eliminate with those doing from sport. Furthermore, you too know that a few competitors may be more uncovered to a doping choice.

The followings are some of the reasons that doping is prohibited. These are;

Cheating:

People or groups in some cases contend that doping is precluded since it is cheating. In sport competition, any individual enters to competition to test his execution with the adversary based on the expertise anticipated by

that specific sport. Hence, when an individual cheats, he is making himself out of the competition. On the off chance that one individual blockheads and another does not, there's no genuine challenge and the point of don has been destroyed.

Harm:

This means when an athlete taking forbidden drugs, there is a risk to harm athletes who do not dope, and harm their society.

Students, keep in mind, not knowing isn't a reason and there's restricted consideration for carelessness in anti-doping. In case you're found doping and confront a boycott from sport that's as it were the starting.

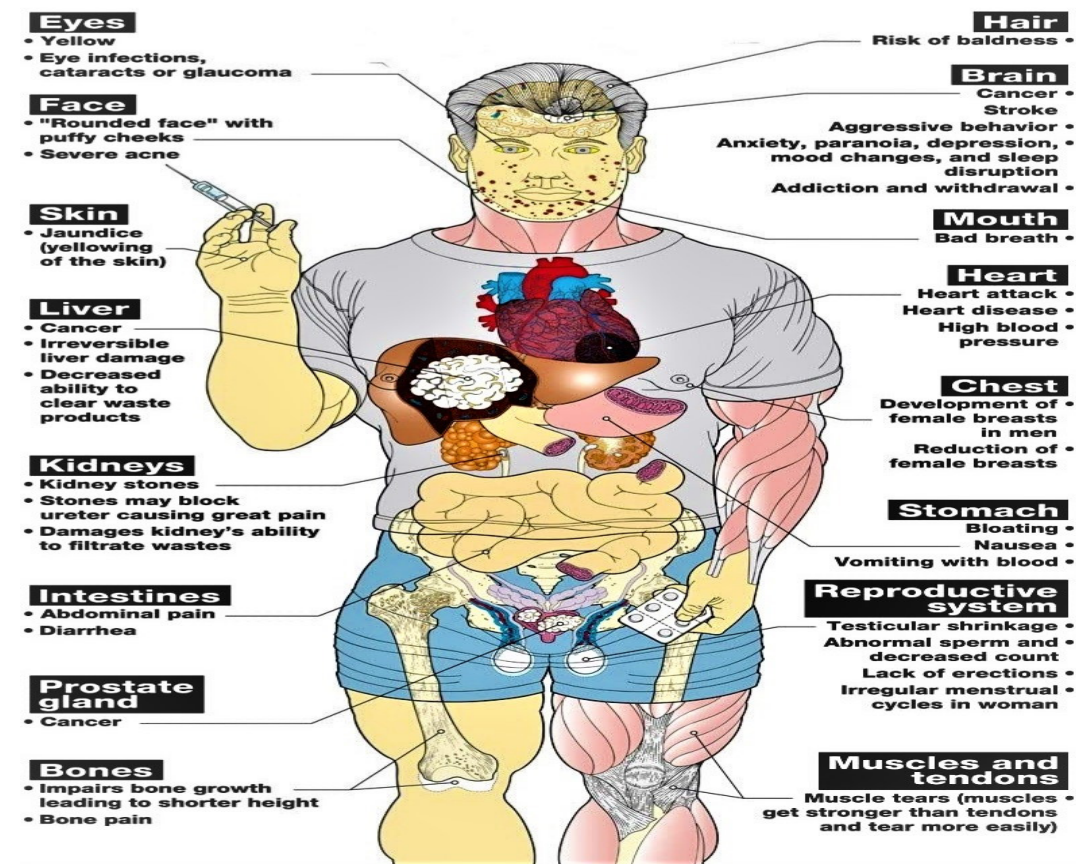

Figure 1.19 Effect of Steroid

The results of doping to your wellbeing, and mental health - as well as the social and money related results - are far-reaching and damaging.

Generally, doping has two major results. These are health consequence and sport consequence sanctions. The use of utilizing drugs or strategies includes infusions which will lead an individual to extra wellbeing dangers. Non-sterile infusion strategies, counting, sharing conceivably sullied needles can raise the hazard of transmission of irresistible illnesses like hepatitis and HIV/AIDS

Activity 1.4.2.

Students, be in pair and discuss on the following issues and reflect to the whole class.

1. What are the impact of doping in an individual health?
2. Why are peoples using doping?

The consequences of doping could spell the termination of the athlete sporting career, his/her status and his/her future prospects both in and out of sport. Thus, athletes should say no for doping. When athletes are using doping and found by the anti-doping agency, the athlete will be punished.

Some of the sanctions for an anti-doping violation can include: disqualification of results at an event, including for feiture of medals, a ban from all sport (competing, training or coaching) for up to four years or even life in repeat or the most serious cases, publication of your anti-doping rule violation and financial penalties.

Advance to those sanctions, a competitor or who has been found blameworthy of an Anti-Doping Run the show

Infringement is frequently uncovered to a level of media consideration which can lead to conclusion in lasting harm to their notoriety.

This implies that stories on the TV news, in daily papers, on social media like Facebook and Twitter which, in cases of consider cheating, might lead on to you being the subject of open disregard. Hence, the society will not acknowledge you as a veritable person.

Doping run the show infringement can put weight not fair on competitors but others near to the competitor such as, companions, accomplices and family. It is these results which are habitually the foremost troublesome for competitors to affect. Doping rule violations can place pressure not just on athletes but others cloth to the athlete such as, friends, partners and family. It is these consequences which are frequently the most difficult for athletes to affect.

Activity 1.4.3.

1. How is world class athletes offended because of doping?
2. Why athletes are prohibited from performance enhancement drugs?
3. What is the impact of drug use on the health of athletes?
3. Students, please consult any sport club related to the consequences of doping and come up with the result and share to the whole class.

Unit summary

In this unit, you have learnt that;

The contribution of sport is vital for economic development of our country, Ethiopia. Top level Athletes of our country, like Haile Gebresilassie,

Derartu Tulu, Kenenisa Bekele, Gezahegn Abera, and others after winning in international sport arena they brought foreign currency for our country. In addition to the foreign currency, they invest huge amount of money in different investment sectors. In these sectors they also create job opportunity for the society. Thus, in one way or another they contribute a lot for the development of the economy of our country.

☞ Gender refers to the female and male differences created by social, cultural, historical and political expectations about behaviour, interests, abilities and attitudes to men and women in sport. Currently, from sport perspectives, females are equal with male in all aspects. You can take the experience of our top level female athletes who contribute a lot for the development of sport.

☞ of sport like, Photo finish camera for Athletics sport, the development of Video Assisting Referee (VAR) to make better the football competition. Technology also plays in the manufacturing of sport wears and sport facilities.

☞ Doping is simply the use of a prohibited substance, but breaking other anti-doping rules is also considered doping. There are Health Consequences of Doping and sport Consequences – sanctions of doping. Thus, as Athlete, it is strictly forbidden to use substances which is categorized as doping by international anti-doping agencies.

☞ Technology plays a tremendous role for the current development in all aspects of sport like, Photo finish camera for Athletics sport, the

development of Video Assisting Referee (VAR) to make better the football competition. Technology also plays in the manufacturing of sport wears and sport facilities.

☞ Doping is simply the use of a prohibited substance, but breaking other anti-doping rules is also considered doping. There are Health Consequences of Doping and sport Consequences – sanctions of doping. Thus, as Athlete, it is strictly forbidden to use substances which is categorized as doping by international anti-doping agencies.

Review Questions

I. Choose the best answer from the given alternatives.

- Who benefits from organizing an event in one kebele, woreda, city, or nation?
 - Hotel owners
 - Transport owners
 - Marketers
 - All
- Who is benefited from gender equality?
 - Female
 - Males
 - Society
 - Nation
 - All
- Which one of the following is the result of technology?
 - Video Assistance Referee
 - Photo-finish camera
 - Sport wears
 - Facilities
 - All
- Why do some Athletes taking prohibited drugs?

- For performance enhancement
- For recreational use
- For medical conditions
- All

II. Read the following questions carefully. Then, discuss with your friends and reflect your answer to the class.

- What are the effects of technology on the development of sport? Please discuss with your friends and reflect to the class.
- Why is it important to learn the effects of a number of different technological advancement in sport?
- As a student of grade 9(male/female), how can you express your idea without hurting other student's (male/female) feelings while participating in different sports?
- Try to think about any sport event that organized in your locality. Who is going to be benefited from that sport event? How do they get a benefited? Please reflect to the class.
- Why is it very important to learn the effects of doping in an individual athlete?
- What relationship do you think has sport with gender and technology?
- Students, please go to in your village sport field or stadium and watch any sport competition. Then, please try to bring information on what kinds of technological advancement they used while playing that game? Then present your findings to the whole class.

UNIT TWO

HEALTH AND PHYSICAL FITNESS

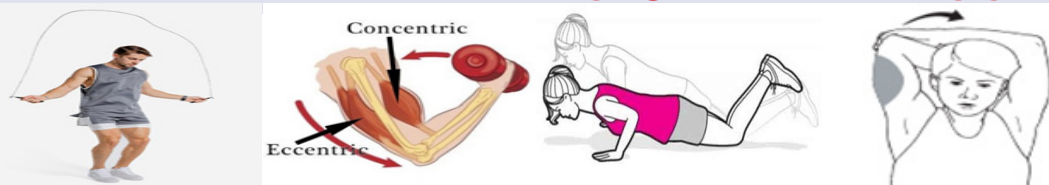

Introduction

Dear students, in your grade 8 textbook of Health and Physical Education you learnt about dimensions of physical education. They include education through movement, education about movement and education in movement. These dimensions improve the student's wellness and health.

Health has been defined by the World Health Organization as a state of complete physical, mental and social well-being, and not merely the absence of disease or infirmity. Physical fitness on the other hand, is defined as a set of attributes that people have or achieve that relates to the ability to perform physical activity of some sort that stimulates various systems of the body and maintains a certain condition within the body. Physical fitness components are classified into health-related physical fitness and skill-related physical fitness. Health-related physical fitness are body composition, cardiorespiratory fitness, flexibility, muscular endurance and strength. Skill-related physical fitness are agility, accuracy, balance, coordination, power and speed.

In your grade 9 textbook, you will learn about body system, hypokinetic diseases and exercise, principles of physical fitness training, exercise which develops cardiovascular endurance, exercise which develops muscular endurance and strength, exercise which develops flexibility and exercise which develops speed.

Unit objectives

At the end of this unit, you will able to:

- ☞ recognize fitness exercise which develops physical fitness and principles of training;
- ☞ understand physical fitness by performing age appropriate fitness exercise and,
- ☞ develop positive attitude to use physical exercise throughout their life.

UNIT CONTENTS

- 2.1. Body system and exercise
- 2.2. Hypokinetic diseases and exercise

2.3.Principles of physical fitness training

2.4. Exercise which develops cardiovascular endurance

2.5 Exercise which develops muscular endurance and strength

2.6. Exercise which develops flexibility

Unit summary

Review questions

2.1. Body system and exercise

Specific objectives

At the end of this lesson, you will be

able to:

- ☞ explain the short-term effects of exercise on cardiovascular, respiratory and muscular systems;
- ☞ identify the long-term effects of exercise on cardiovascular, respiratory and muscular systems and,
- ☞ mention the fundamentals of body system utilization of energy during exercise.

Start-up activity 2.1.1

1. What do you observe on your body systems when you start an exercise?
2. What are the components of cardiovascular systems?
3. Do you have any feeling on your cardiovascular system while you are participating in health and physical education practical class?

2.1.1 Human body system

The human body is a biological machine made of body systems. It is groups of organs that work together to produce and sustain life. The human bodies are made up of eleven (11) basic organ systems that manage all the essential body functions. These are the skeletal, nervous, muscular respiratory, endocrine, immune, cardiovascular/circulatory, urinary, integumentary, reproductive and digestive systems. Here we focus on the main important part of body systems which are cardiovascular system, respiratory system and muscular system. Moreover, we also discuss what happen while we perform exercise.

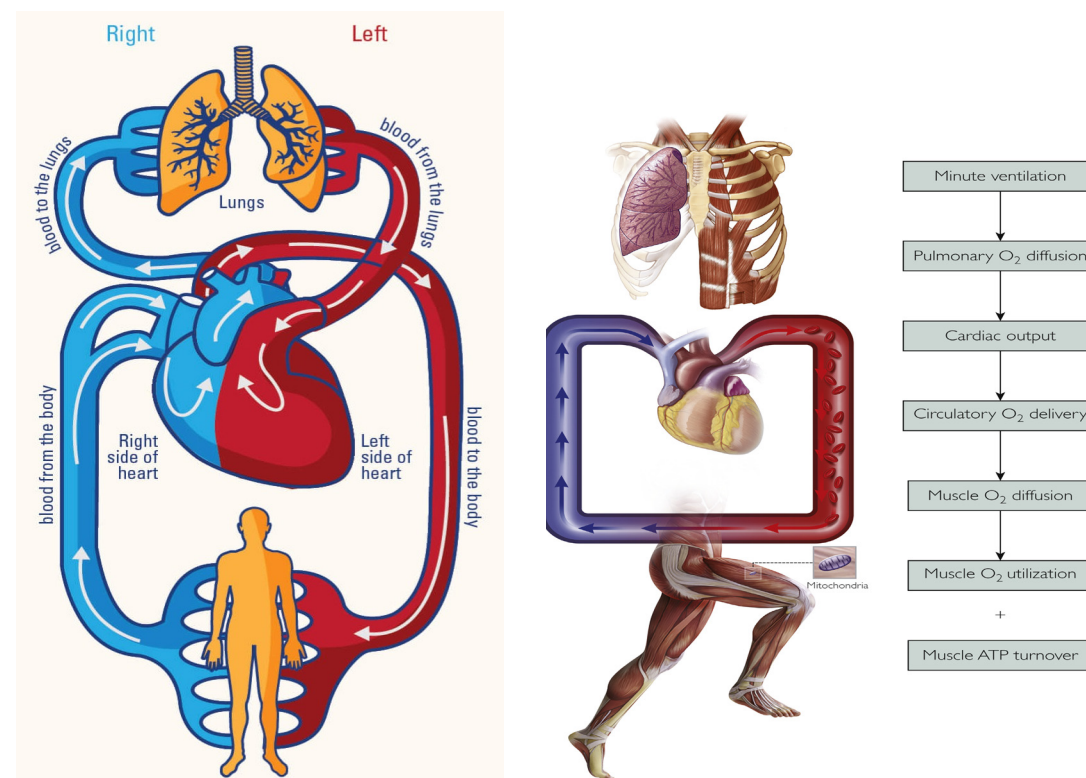

Figure 2.1 The connection and function of heart, lung and muscle during exercise

2.1.1.1 Cardiovascular system responses to exercise

All types of human movement require an expenditure of energy above resting values. Much of this energy comes from the use of oxygen. To supply the working muscles with the needed oxygen, the cardiovascular and respiratory systems work together.

Aerobic exercise means working with oxygen which requires more energy. Therefore, our body needs more oxygen. How much oxygen is needed depends primarily on the intensity of the activity and its duration length.

Activity 2.1.2 ?

Manual pulse rate measurements

Method 1: Radial pulse

Dear students, here you try to measure your radial artery pulse rate by using the procedure indicated below. First identify the place your radial artery is found. It is found around your wrist joint.

Place your pointer and middle fingers on the inside of your opposite wrist just below the thumb.

1. Don't use your thumb to check your pulse, as the artery in your thumb can make it harder to count accurately.
2. Once you feel your pulse, count how many beats you feel in 15 seconds.
3. Multiply this number by 4 to get your heart rate. For instance, 20 beats in 15 seconds equals a heart rate of 80 beats per minute (bpm).



Figure 2.2
Manual pulse rate measurement of radial

Activity 2.1.3 ?

Manual pulse rate measurements

Method 2: Carotid pulse

Here you are expected to measure your carotid pulse rate by using the procedure indicated below. First find the place your carotid artery is found. It is found around your neck.

- Place your pointer and middle fingers on the side of your windpipe just below the jawbone. You may need to shift your fingers until you can easily feel your heart beating.
- Count the pulses you feel for 15 seconds by using wristwatch, stop watch and mobile phone.
- Multiply this number by 4 to obtain your heart rate.



Figure 2.3 Manual pulse rate measurement of carotid pulse

Activity 2.1.4

Method 3: Heart rate monitors technology

Heart rate monitors work by using electrocardiogram (EKG) techniques that use, for instance, electrodes attached to a chest strap, which transmit the heart rate to a wrist receiver via telemetry (or, remote transmission of data).

- During an EKG, electrical activity of the heart is measured over a period of time with skin electrodes and recorded to a device for later analysis.



Figure 2.4 A man wears a heart rate monitor around his torso and wrist while exercising

2.1.2. Respiratory system responses to exercise

The function of the respiratory system is to increase blood flow for the cardiovascular system and oxygen delivery to contracting muscles. The primary functions of the respiratory system during exercise are to maintain arterial oxygen saturation and facilitate the removal of carbon dioxide from contracting muscles.

Activity 2.1.5 ?

Method 4: Mobile phone technology heart rate measurements

- Measure your own heart rate levels by using mobile phone techniques prior exercise and immediately at the end of exercise program.
- Measure your own heart rate after one (1) minute exercise program, 2.5 minutes and 3.5 minutes. With each heart rate measurement there is one (1) minute interval.

2.1.3. Muscular system responses to exercise

When the muscles start to work, they need more oxygen. So the respiratory system responds by getting more oxygen into the lungs. The blood carries greater amounts of oxygen and the heart responds to pump more oxygenated blood around the body.

After exercising, the muscles need to rest, adapt and recover.

2.2. Hypokinetic diseases and exercise

Specific objectives

At the end of this lesson, you will be able to:

- describe the role of physical exercise on hypokinetic diseases;
- list types of hypokinetic diseases and,
- perform different types of exercise to develop protect hypokinetic diseases.

Start-up activity 2.2.1 ?

1. Have you ever heard about hypokinetic diseases before? Share what you know about it for your classmate.
2. What are the similarities and difference between non-communicable diseases and communicable diseases? How do they differ regarding: infectiousness and risk of disease?
3. To which type of disease do cancer classified? How about influenza?
4. Do you know an individual who suffer from non-communicable diseases around your environment. Does s/he do an exercise?

Hypokinetic disease also known as non-communicable disease, tend to be of long duration and are the result of a combination of genetic, physiological, environmental and behavioural factors. A hypokinetic disease is a disease that is happened with absence of exercise or too little of exercise. Types of hypokinetic are cardiovascular disease, cancer, chronic respiratory disease, diabetes, chronic neurologic disorders, arthritis/ musculoskeletal diseases and unintentional injuries.

2.2.1 Physical exercise interventions and its benefits

Physical exercise is a subset of physical activity, which is planned, structured, and repetitive aimed to improve or maintaining fitness or health. According to American College Sport Medicine (2009) physical activity is a universal concept and defined as bodily movement produced by the contraction of skeletal muscles that substantially increases the amount of energy you expend.

Physical activity is an organized activity and is further divided into different categories according to the purpose. Primarily physical activity is aimed at physical and health capacity improvement.

According to the World Health Organization, the first indicator of health is physical activity at the community level. The risk of many chronic diseases such as cancer, cardiovascular condition, and diabetes (type 2) are reduced through regular physical activity. The sedentary lifestyle is the leading cause of the increased mortality rate globally. WHO stated that about 3.2 million deaths per year are occurring due to physical inactivity across the world.

It is important to plan physical activity interventions with the aim of preventing and managing hypokinetic (NCDs). No single intervention is effective to increase physical activity level; instead a comprehensive collaborative approach is most effective. Interventions should be easy, simple, cheap, social and sustainable across the life span.

2.3. Principles of physical fitness training

Specific objectives

At the end of this lesson, you will be able to:

- ☞ identify the basic principles of physical fitness training and,
- ☞ describe the principles involved in designing a well-rounded exercise program.

Start-up activity 2.3.1

1. Does your current lifestyle include enough physical activity for 30 minutes which is moderate-intensity for five or more days a week to support health and wellness?
2. Does your lifestyle go beyond this level to include enough vigorous physical activity and exercise to build physical fitness?
3. Mention for your classmate some principles of physical fitness training.

In your grade eight Health and Physical Education you learned about physical fitness and defined the term as the body's ability to function effectively and efficiently which contributes the total quality of life. People vary greatly in physical fitness and performance ability. These also differ in conception of the benefits of regular exercise. Physical fitness and athletic achievement are not limited to the able-bodied. People with disabilities can also attain high levels of fitness and performance, as shown by the elite athletes who compete in the Paralympics.

The human body is very adaptable to the incoming activity as stress. The body response to exercise is two types.

The first one is the immediate response (acute response) while the person starts the exercise the body system mechanism tries to overcome the challenges by increasing heart rate, inhalation and exhalation and increasing blood circulation toward active part of the muscle. The second one is chronic adaptation of exercise. For chronic adaptation of exercise to be effective it needs planning and repetition of activity in structured way.

Here you are familiarizing with some basic principles of training of specificity, progressive overload, reversibility and individual differences.

Activity 2.3.2

Discuss on how your routine exercise contributed to the four principles of training.

2.3.1 The principle of specificity

Every activity requires a specific mix of fitness components. And the training you undertake needs to reflect the contribution made by each component. To develop a particular fitness component, you must perform exercises that are designed specifically for that component.

2.3.2 The principle of overload

The whole point of training is to improve your level of fitness. But you improve your level of fitness only if you overload your body. In other words, you make your body work harder than normal by increasing the amount of work it has to perform. The body will then gradually adapt to the new level of work and your level of fitness will improve.

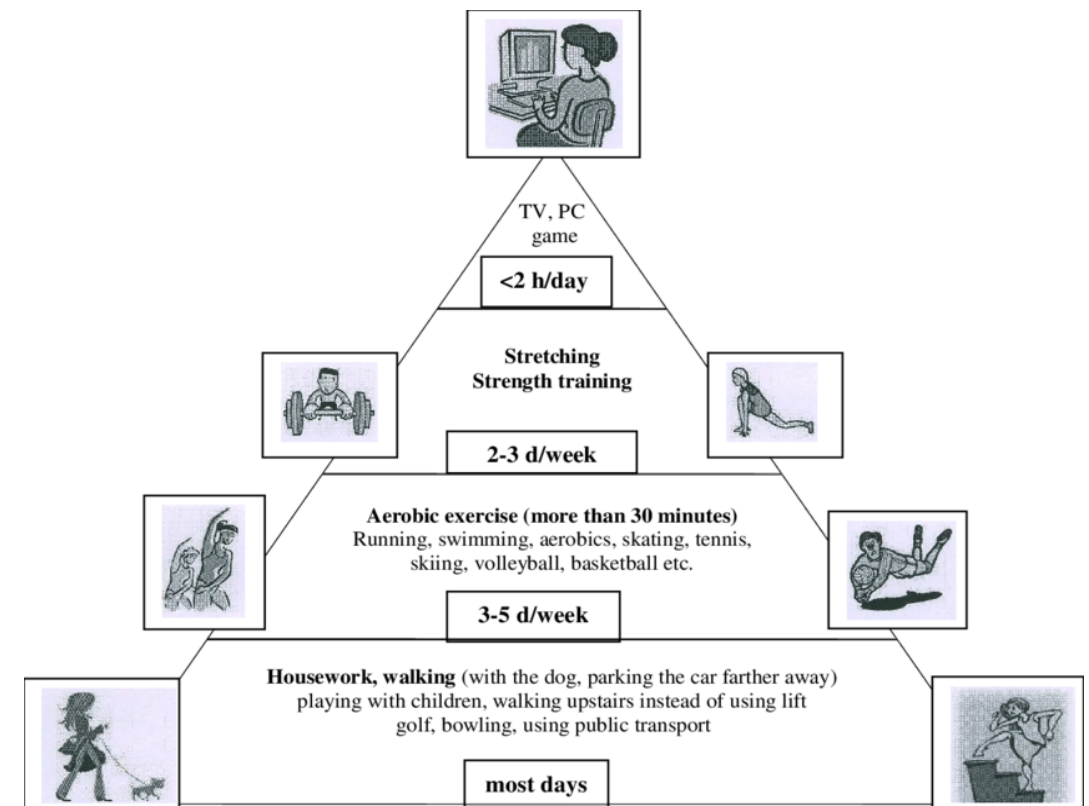

Figure 2.5 Physical activity pyramid

The amount of exercise needed depends on the individual's current level of fitness, the person's genetically determined capacity to adapt to training, his or her fitness goals, and the component being developed.

2.3.3 The principle of reversibility

Fitness cannot be stored for future use and your level of fitness is constantly changing. Any adaptations that take place as a consequence of training will be reversed when you stop training; this is sometimes referred to as detraining.

2.3.4 The principle of individual differences

The principle of individual difference is a principle that states that, because everyone is unique, each person experiences a different response to an exercise program. Some of these differences may be related to body size and shape, genetics, past experience, chronic conditions, injuries and gender. For example, some people need longer recovery time than others.

2.4. Exercise which develops cardiovascular endurance

Specific objectives

At the end of this lesson, you will be able to:

- ☞ explain the relationships between cardiovascular system and exercise;
- ☞ list the major effects and benefits cardiovascular endurance and,
- ☞ perform different physical exercises which improve your cardiovascular endurance.

Start-up activity 2.4.1 ?

1. Students will be in pair and share their own engagement and observation about cardiovascular exercise.
2. Show some exercises which are developing cardiovascular endurance to your classmates.
3. What are the differences between trained and untried exercise program participant's recovery rates?

A basic understanding of the body processes involved in cardiovascular exercise can help you design a safe effective fitness program. Cardiovascular endurance, some times called cardiorespiratory endurance, which is the body parts, serves to work continuously for extended periods of time. The cardiovascular system picks up and transport oxygen, nutrients, and other key substances to the organs and tissues that need them. It also picks up waste products and carries them to where they can be used or expelled.

The cardiovascular system consists of the heart, the blood vessels and the respiratory system. Walking, jogging, running and biking are a few examples of aerobic activities. Aerobic activities strengthen the heart and lungs, and make your working muscles more efficient at using oxygen. They also increase stroke volume (amount of blood pumped per heartbeat) and lower your resting heart rate to an average of 72 bpm (beats per minute).

FITT is an abbreviation and principle of training (F stands for frequency, I stand for intensity, T stand for time (duration) and T stand for type of activity).

Frequency is how often the exercise pro

gram performs per week for benefits are achieved when you engage in exercise three to five times per week.

Intensity refers to how hard the exercise program of your target heart rate (THR) zone is. In general, it is exercising at a level where the heart is beating between 50% and 85% of a person's maximum heart rate (220 minus age).

Exercise designed to improve cardiovascular fitness works to improve the heart's ability to pump blood and the muscle's ability to pull oxygen from the blood.

Time (duration) is how long the exercise program in your target heart rate zone is.

Type of exercise is the types of activities that provide the greatest improvements in cardiovascular fitness.

Activity 2.4.2 ?

1. Get in to groups and perform skipping or jumping exercise on standing position.
2. Practice different styles of skipping activities ((double and single) exercise.

2.4.1 Methods of train cardiovascular endurance

Cardiovascular endurance exercise consists of prolonged low-to-medium resistance training that puts your cardiorespiratory system (heart, lungs and veins) to the test. This means that your heart rate remains elevated throughout the whole duration of the exercise and is heavily related to how well you can provide oxygen to your muscles and remove carbon dioxide. Along with light training, some of the best methods to improve your cardio are jumping rope, aerobics exercise,

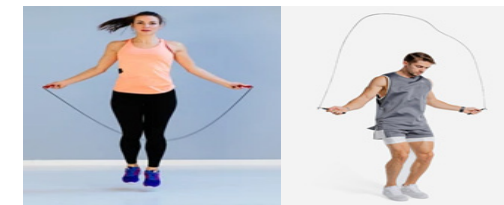

Figure 2.6 Skipping rope activity to develop cardiovascular endurance

Aerobic exercise

It is also known as endurance activities, cardio or cardio-respiratory exercise.

It is physical exercise of low to high intensity that depends primarily on the aerobic energy-generating process.



Figure 2.7 Aerobic exercise program to develop cardiovascular endurance

Walking is a great way to improve or maintain your overall health. Just 30 minutes every day can increase cardiovascular fitness, strengthen bones, reduce excess body fat, and boost muscle power and endurance.



Figure 2.8 Walking activity to develop cardiovascular endurance

Jogging

It is a step which simply means running with a slower speed. It's between



Figure 2.9 Jogging activities to develop cardiovascular endurance

walking and running to increase your fitness with less stress on your body. Jogging is a proven method for improving and maintaining cardiovascular fitness.

Running is probably the easiest and most versatile exercise to improve your cardiovascular endurance. While running can be used to slowly build strength basis for more intense and challenging tasks, its biggest benefit is its ability to strengthen your heart.

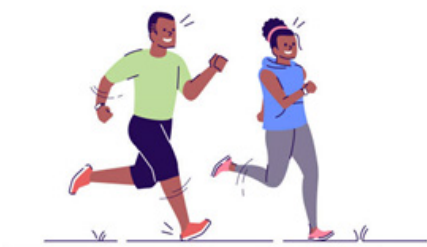

Figure 2.10 Running activity to develop cardiovascular endurance

Suggestions

Perform walking, jogging, running, rope skipping, swimming, aerobic dances and picnic travel exercise to develop your cardiovascular endurance in your spare time in your surroundings.

2.5. Exercise to develops muscular endurance and strength

Specific objectives

At the end of this lesson, you will be able to:

- ☞ define muscular strength and endurance and how they relate to health;
- ☞ describe the relationship between muscular strength and muscular endurance with health and,
- ☞ explain how one safely perform common strength training exercises using weight and free weights.

Start-up activity 2.5.1 ?

1. List four benefits of muscular strength and endurance that are particularly meaningful to you.
2. Post the list in an appropriate location and use as a motivational tool for beginning and maintaining your muscular strength and endurance training program.
3. Practice muscular strength and endurance exercises in your home.

2.5.1 How a muscle works?

Muscles produce the force required for movement within the body. The nervous system coordinates the muscular contractions of the muscles to allow us to carry out everyday tasks and bodily functions. Movement can be caused by the contraction of skeletal muscle, resulting in the movement of the body or body part. It can be caused by the contraction of smooth muscle, resulting in such things as food being moved through the digestive system, or it can be the contraction of cardiac muscle, resulting in the movement of blood through the cardiovascular system.

There are two types of muscle contraction. Based on the functions that the muscle is performing they are named as concentric and eccentric contraction.

Concentric contraction

It is the most common form of muscular contraction. It occurs when a muscle is as a prime mover and shortening under tension and creating movement around a joint.

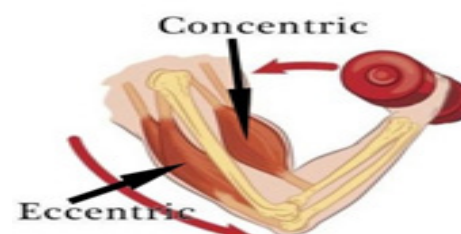

Figure 2.11 Concentric contraction

Eccentric contraction

It is the opposite of concentric action. In eccentric contraction the muscle acts as antagonist lengthens under tension.

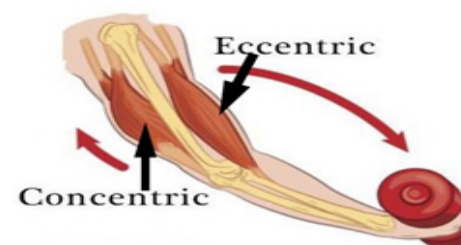

Figure 2.12 Eccentric contraction

There are three types of muscular strength and endurance training.

Isotonic type of program

There is concentric and eccentric contraction which generally involves the full range of motion. And also there is shortening and lengthening of muscle.

Isometric type of program

contraction is the muscle increases in tension but there is no change in its length and therefore no movement.

a muscle is acting as a fixator or when it is working against a resistance that cannot overcome. The development of strength and endurance is specific to the joint angle at which the muscle group is trained.



Figure 2.13 wall press- Isometric contraction

Isokinetic type of program:

This type of contraction is a type of muscle contraction where the muscle shortens and increases in tension while working at a constant speed against a variable resistance. The muscle works throughout the full range of movement but this can be achieved only by using isokinetic weight training program.

2.5.2 Training for strength versus endurance

Muscular strength and muscular endurance are different but related components of muscle fitness. Muscular strength is the maximum amount of force a muscle can produce in a single effort. The way of assessment is measuring the maximum amount of weight an individual lift once. On the other hand, muscular endurance is the ability of a muscle to apply a submaximal force continuously for long period of time without fatigue.

Weight training program specifically is designed to improve strength and program designed to improve muscle

ular endurance differ mainly in the number of repetition and the amount of resistance. Weight training program using low repetitions and high resistance results in the greatest strength gains, whereas a weight training program using high repetitions and low resistance results in the greatest improvement in muscular endurance.

Activity 2.5.2

1. Form groups and performs plank, body weight, walking lunges, push-ups and sit ups of five stations for 30 seconds. Use 10 seconds interval between each station to develop your muscular endurance and strength.
2. Practice muscular endurance and strength at home.

Modified push-up

Procedure

- a. Shoulder-width apart places your hands on the floor and your fingertips facing forward.
- b. Keep your head, neck and spine in line.
- c. Bend your knees.
- d. Slowly lower down to the floor, to the point right before your nose touches the floor.
- e. Pause and slowly lift your body weight back up to the starting position.
- f. Do modified push-up 8-12 repetitions.

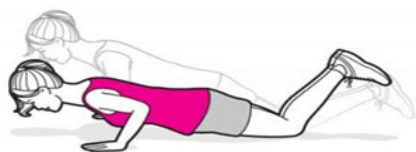

Figure 2.15 Modified push-up

Advanced push-up

Procedure

- a. Shoulder-width apart places your hands

- a. on the floor and your fingertips facing forward.
- b. Keep your head, neck and spine in line.
- c. Extend your legs behind you, with your toes pointing down and the balls of your feet on the floor.
- d. Slowly lower your body down to the floor, to the point right before your nose touches the floor.
- e. Pause and slowly lift back up to the starting position.

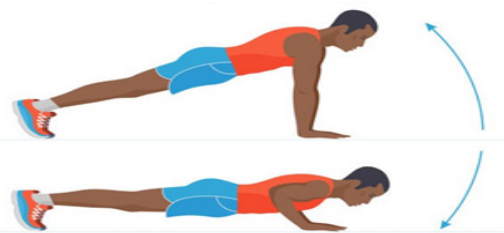

Figure 2.16 Advanced push-up

Squat with weights

Procedure

- a. Start by standing with your feet shoulder-width apart, knees slightly bent.
 - b. Slowly lower your body, with the hips moving back as if sitting on a chair.
 - c. Keep your weight directly over the heels.
 - d. Bend your knees about 90 degrees.
 - e. Pause, and then slowly return to the starting position.
1. Do 8-12 repetitions

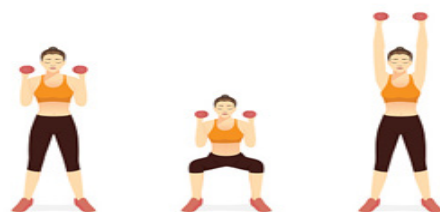

Figure 2.17 Squat with weight

Suggestion

Evaluate each other with your colleague after performing the following exercise which develop muscular endurance and strength in your spare time.

- a. Squatting with own-weight
- b. Squatting holding easy weights
- c. Upper body exercise (back lift, chest push, and pull-up)
- d. Abdominal exercise (sitting tucks, trunk lift and crunch/curl up)
- e. Lower body exercise (flexed arm support, ninety-degree push-up and whist)

2.6. Exercise which develops flexibility

Specific objectives

At the end of this lesson, you will be able to:

- ☞ identify the benefit of flexibility to health total fitness and performance;
- ☞ perform different types of flexibility exercise
- ☞ select appropriate exercises which develop flexibility and,
- ☞ execute dynamic and static stretching exercises to maintain the level flexibility.

Start-up activity 2.6.1

1. What are the health benefits of flexibility?
2. Do you know the influential factors of flexibility?
3. Show exercise which are developing flexibility for your classmates.

Flexibility is improved by stretching, moving a joints extend beyond its point of resistance. Flexibility is restricted by the joint itself and the muscles, ligaments and tendons acting on it.

Dynamic stretches is an individual mus

cles and joints manage the activity with a great range of motion. Stretching exercise engagements in continuous work out provide readiness for main part of the activities. This enhances performance and decreases injury risk by improving blood flow to the muscles.

Static stretching is achieved when you are actively moving into a position that takes the joints beyond its point of resistance, lengthening the soft tissue around your joint.

Static stretches are those in which you stand, sit or lie still and hold a single position for period of time a minimum of ten seconds.

Activity 2.6.2

1. Get into groups and perform dynamic and static stretching exercises.
2. Get into pair to practice flexibility exercises and demonstrate it for your classmates.

2.6.1 Dynamic stretching

2.6.1.1 Walking high knees

The purpose of this stretching is to flex the hips and shoulders, and stretch the gluteus, quads, lower back and shoulders.

Procedure

- a. Take high step right and left foot turn by turn. As much as possible try to pick it up your knee, and at the same time push up on the toes of your opposite foot;
- b. Synchronized your foot raise and hand swing right and left respectively; your elbow angle should be ninety degree, your hands should be swing hands up to chin level and back beyond rear pocket and,
- c. Drive your knees up as much as possible



Figure 2.18 Walking high knees

2.6.1.2 Walking straight leg kicks

The purpose of this stretching is to stretch the hamstrings, calves and lower back.

Procedure

- a. Walk forward keeping your front leg straight;
- b. Kick your leg up and touch your toes to the fingers of your opposite hand;
- c. Repeat the cycle with your opposite leg;
- c. Keep your arm extended out parallel with the ground and,
- d. On your first set of this drill only kick to 75% capacity, and then on your second set kick to full capacity.



Figure 2.19 Walking straight leg kicks

2.6.2 Static stretch

2.6.2.1 Walking lunge

The purpose of this stretching is to stretch the gluteus, hamstrings, hip flexors and calves. Student's practicing this walking lunge activity in pair following procedures.

Procedure

- a. Step out with a long stride, striking the heel of your forward foot and extending

- onto the toes of your back foot;
- b. Complete the cycle by bringing your trail leg through and standing upright;
- c. Position your hands behind your head while keeping your eyes focused forward and,
- d. Flex your front knee to 90 and keep your back knee from striking the ground.



Figure 2.20 Walking lunge

2.6.2.2 Walking side lunge

The purpose of this stretching is to stretch the groin, gluteus, hamstrings, and ankles.

Procedure

- a. Keep your torso upright and take a long stride out to the side;
- b. Lunge out bending your forward knee to ninety degree while keeping your trail leg straight;
- c. Lower your hips and shift your body weight to the opposite leg;
- f. Recover by bringing your feet together and standing upright;
- g. Repeat the drill for 15 meters and
- h. Keep your head focused forward with your arms hanging down in front of your body.

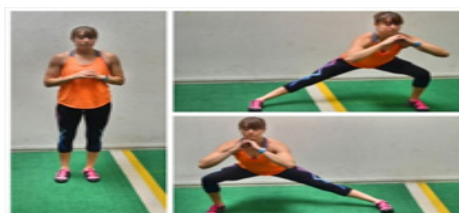

Figure 2.21 Walking side lunge

2.6.2.3 Side bends

The purpose of side bends is to stretch the triceps, upper back, abdominal, and oblique.

Procedure

- a. Bend to one side while holding your opposite arm overhead, quickly reverse direction and stretch the other side and
- b. This drill should be done in a controlled continuous fashion for 10 stretches on each side of your body.



Figure 2.22 Side bends

2.6.2.4 Triceps stretching

The purpose of this stretching is to stretch the triceps muscles.

Procedure

- a. Bend elbow and place hand of bent arm on back of neck;
- b. Using the other hand, pull elbow behind head and
- c. Hold for 20-30 seconds and repeat two or



Figure 2.23 Triceps stretching

2.6.2.5 Quadriceps stretching

The purpose of this stretching is to stretch the quadriceps muscles.

Procedure:

- a. Lie on side with knees bent and holds

top foot with same-side hand;

- b. Pull heel in toward buttock, keeping knees in line and hip pressed forward and



Figure 2.24 Quadriceps stretching

2.6.2.6 Lumbar extensor stretching

The purpose of this exercise is to stretch the lumbar extensor back muscles.

Procedure

- a. With head raised up and lower back slightly arched, tuck chin to chest and round back toward ceiling;
- b. Return to starting position;
- c. Hold the arched and round back positions briefly and
- d. Hold for 20-30 seconds and repeat two



Figure 2.25 Lumbar extensor stretching

Activity 2.6.2.6.1

1. Practice exercises which help to develop trunk flexibility.
2. Practice exercises which help to develop shoulder flexibility.
3. Select and perform appropriate Ethiopia cultural games which develop flexibility.
4. Organize and arrange weekly regular

exercise program with your friends in your surroundings.

5. Take a shower as soon as possible after an exercise session.

Key words:

Cardiovascular endurance, Frequency, Intensity, Isometric contraction, Isotonic contraction, Muscular endurance, Muscular strength, and Radial pulse

Unit summary

☞ Physical fitness is a person's ability to meet the physical stresses and demands of a variety of physical activities efficiently and effectively. The five components of physical fitness which are of most important for health are cardiorespiratory endurance, muscular strength, muscular endurance, flexibility, and body composition. Physical training is the process of producing long-term improvements in the body's functioning through exercise. Bodies adapt to progressive overload when progressively increase the frequency, intensity, and time (duration) of the right type of exercise, you become increasingly fit.

☞ People vary in the maximum level of fitness they can achieve. Design an exercise program, determine if medical clearance is needed, assess the current level of fitness, set realistic goals, and choose activities that develop all the components of fitness.

☞ Hypokinetic disease is associated with lack of physical activity or little regular exercise.

☞ The cardiovascular system is composed of the heart, the vasculature, and the blood. The primary functions

Unit review questions

I. Multiple choice items

- The amount of overload needed to maintain a particular level of fitness for a particular fitness component is determined through four dimensions. The acronym "FITT" represent _____.
 - How long
 - How hard
 - How often
 - Mode of activity
- Which of the following is not considered a health-related fitness component?
 - Muscular endurance
 - Flexibility
 - Cardiorespiratory endurance
 - Agility
- One of the following is not categorized under non-communicable diseases (NCDs).
 - Tuberculosis
 - Cardiovascular disease
 - Diabetes -2
 - Cancer
- What typically happens to muscle temperature during a warm up?
 - Remain constant
 - Increases
 - Decreases
- Which of the following adaptations to training is an effect on the skeletal system?
 - Increased vital capacity
 - Increase in red blood cells
 - Increased bone density
- One of the following is different from the other.
 - Strength training
 - Endurance training
 - Resistance training
 - Weight training

- Strength training
 - Endurance training
 - Resistance training
 - Weight training
- Developed strength and endurance cannot lead to improvement of _____.
 - Chronic disease development
 - Injury prevention
 - Muscle and bone health
 - Self-image
 - Isometric exercise is the one in which muscle length is _____.
 - Constant
 - Shortened
 - Lengthen
 - None of the above
 - Aerobic fitness is best achieved through _____.
 - Swimming
 - Circuit training
 - Short sprints
 - Long distance running
- #### II. Think over it
- What are the differences between hypokinetic diseases and communicable diseases?
 - What is the benefit of physical activity for those individuals participating in regular exercise program?
 - Do you feel that you will use stretching exercises as part of your regular lifetime physical activity plan, either at present or the future?
 - Do you feel that you will use muscle fitness exercises as part of your regular lifetime physical activity plan, either at present or the future?
 - Discuss your current level of cardiovascular fitness and steps that you should take in the future to maintain or improve it.
 - Discuss the exercises that you feel benefited you and the once that did not. What modifications would be made in your program for it to work better for you?
 - List your own feeling while participating in exercise regular program during health and physical education class on the responses of cardiovascular and respiratory systems.

UNIT THREE

ATHLETICS

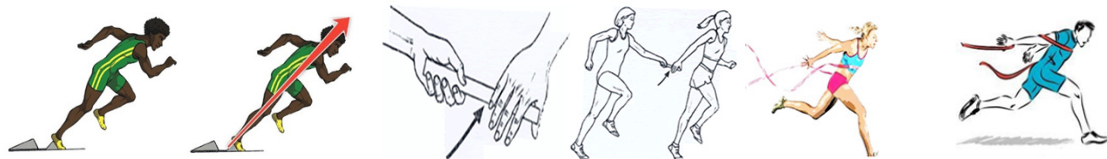

Introduction

Historians estimated that athletics begun in 10th and 9th B.C in Greece. Athletics became a popular program in Olympia, Greece. It is one of the oldest types of structured sport. It includes the natural form of activities such as running, walking, jumping, and throwing. In your grade 8 Health and Physical Education you learned about fundamental skills of athletics specifically long jumping techniques, differentiate the patterns of movement during long jumping for height and distance, approach run towards the landing area/pit by using maximum speed and throwing techniques comparing to long jump technique. In this unit you will be learning about brief history of athletics in Ethiopia and Africa, sprint and sprint relay, basic sprint techniques and basic relay techniques will be addressed.

Unit objectives

At the end of this unit, you will able to:

- ☞ demonstrate basic sprint techniques as a component of sprint;
- ☞ demonstrate basic sprint relay techniques as a component of sprint relay;
- ☞ apply sprint starting techniques as they relate to sprinting;
- ☞ apply baton exchange techniques as part of sprint relay;
- ☞ show cooperation with partners and teammates to solve problems and
- ☞ appreciate the arts in sprint and spring relay.

UNIT CONTENTS

- 3.1 History of athletics
 - 3.1.1 Brief history of athletics in Ethiopia
 - 3.1.2 Brief history of athletics in Africa
- 3.2 Sprint and sprint relay

3.2.1 Basic sprint techniques

3.2.2 Basic relay techniques

Unit summary

Review question

3.1 History of athletics

Specific objectives

At the end of this lesson, you will be able to:

- ☞ list major athletics historic events in Ethiopia and Africa and,
- ☞ identify the participation of Ethiopia and African athletes in different world wide computation and their success.

3.1.1 Brief History of Athletics in Ethiopia

Ethiopia has enjoyed a rich tradition of producing some of the world's fastest distance runners over the past decades. The country has had a healthy rivalry with East African neighbor Kenya and this has spurred each nation to achieve quicker times on both track and road.

Abebe Bikila was the star of marathon running during the 1960s, winning gold at the 1960 and 1964 Olympics and setting a World Record at the latter Games (2:12:11). Haile Gebreselassie and Kenenisa Bekele can rightly claim to be the dominant forces in global distance running in the past decades, particularly on the track, where they hold the all-time fastest times over both 5000m and 10,000m on multiple occasions.

Meseret Defar in her racing prime was a World and Olympic 5000m Champion. Tsegay Kebede epitomizes consistency in the marathon and rarely runs a poor race. Tirunesh Dibaba won double gold in Beijing over 5000m/10,000m and is one of the world's greatest distance runners in history. She took Olympic gold of 10,000m at the 2012 Olympics.

3.1.2 Brief history of athletics in Africa

The African athletics sport organizing body, the Confederation of African Athletics (CAA) was established in 1973. The main responsibility of the Confederation of African Athletics here after CAA organizes different tasks of the institution and continental athletics competitions. Now a days CAA has 54 member countries and it's headquarter is in Dakar, Senegal.

There are African athletes who made a huge contribution to the sport, with the continent's illustrious history stretching back to even before the formation of the previous International Association of Athletics Federations (IAAF) the current World Athletics (WA).

A pivotal point was the famous barefoot

marathon victory by Ethiopia's Abebe Bikila at the 1960 Olympic Games in Rome, striding through the night sky to equal the world best time. Abebe Bikila, this time wearing shoes, retained his title in Tokyo four years later with another world record in Rome Olympic, Italy. Abebe Bikila was the first black African men to win Olympic gold medal.

Kenya made its mark at the 1968 Olympics in Mexico City with Kip Keino capturing the hearts of athletics devotees with his courageous front running to win the 1500 meter.

In the 1970s, Africa gave the world several great champions and world record setters like Uganda's 400 meter hurdler John Akii-Bua and Tanzania's 1500 m runner and steeplechaser Filbert Bayi. At the 1980 Moscow Olympics, the 5000 meter and 10,000 meter champion Miruts Yifter took the headlines. In the decade as a whole it was Morocco's Said Aouita who took the publicity with five World records over various distances including being the first man to run 5000 meter in under 13 minutes. Ethiopia's Haile Gebrselassie and his compatriot Kenenisa Bekele have then taken 5000 meter and 10,000 meter running to new levels in the last 20 years, with both men also winning a many of World and Olympic titles.



Figure 3; 1 Athlete Abebe Bikila (Rome Olympic gGame-1960)

Africa's women, despite often facing social and cultural barriers, quickly followed in the footsteps of their male counterparts. The 1992 Olympics in Barcelona was another watershed for Africa's women where Derartu Tulu won the game for the first time. Algeria's Hassiba Boulmerka followed her 1500 meter victory at the 1991 world championships with another title, while the 10,000 meter saw a titanic battle in which Ethiopia's Derartu Tulu prevailed over South Africa's Elana Meyer. Derartu made history to become the first black symbolic shared victory lap to provide a memorable image which symbolized a new era of unity for Africa.

Other great African women athletes of recent include Mozambique's Maria Mutola, the 2000 Olympic champion who won the IAAF World Championships 800 m on three occasions. She was even more dominating at the IAAF World Indoor Championships with seven victories. Kenya's Catherine Ndereba won two World titles at the marathon and also set a World record over the classic distance, while Ethiopia's Tirunesh Dibaba was a multiple World champion on the track and at cross country, something which Vivian Cheruiyot succeeded at in 2011.

Activity 3.1 ?

Read about the history of Ethiopia and Africa athletics from reliable sources such as books, newspapers, magazines, and write a short biography of known athletes and present it to your classmates.

3.2 Sprint and Sprint Relay

Track event is a sport comprising various competitive athletic contests based on running. Individual sports with athletes challenge each other to decide a single victory. The racing events are won by the athlete with the fastest time.

Sprinting or short distance running events start from a crouched position. In crouch start, to have a firm support of the feet starting block is needed. If starting blocks are not available in your schools, you can prepare starting block from locally available materials. Starting blocks use for all races up to and including 400 m including the 4 x 100 m and 4 x 400 m and may not be used for any other race.

Relay races are the track event in which a team of runners directly compete against other teams. Typically, a team is made up of four runners of the same sex. Each runner completes their specified distance before handing over a baton to a team mate, who then begins their leg upon receiving the baton. The running events are categorized as sprints, middle and long-distance events, relays, and hurdling.

3.2.1 Basic sprint techniques

Specific objectives

At the end of this lesson, you will be able to:

- ☞ perform a specified distance with change of speed of run and,
- ☞ practice running speeds in group.

Sprinting events are focused around athletes reaching and sustaining their quickest possible running speed. Spiriting race category includes distances up to 400 meters. Three sprinting events are currently held at the Olympics

Outdoor World Championships 100 meters (m), 200 m, and 400 m. Sprinting is the art of running as fast as possible. Power and coordination are the essential ingredients in the production of speed. Coordination can be improved through practicing good running mechanics. Speed is mostly an inherent factor. However, both coordination and speed can be improved through proper training. Mechanics of running is explained in the running basics section.

Basic sprint techniques are classified into four phases. These are start, acceleration, maintaining momentum and the finish.

Activity 3.2.1.1 ?

1. Practicing in pair using different starting positions of sitting, lying, kneeling, and set.
2. Groups (of 3 or 4 students) line up behind a straight line. On the signal, the first member of each group sprints to the end line or cone set 10–15 m away and turn back to the starting line. Perform pivot quickly and accelerate as fast as each student's ability, to return back safely.
3. Assess yourself with your friend's feedback about the performance of spiriting over varying distances (20 - 100 m) without the starting blocks.
3. Assess yourself with your friend's feedback the performance of spirit start and acceleration from the blocks.

Start phase

The start of a race is marked by a white line 5 cm wide. The start is a series of complicated motor skills that, when executed properly, produce the force necessary to overcome inertia and

begin acceleration. Often occurring in less than one second; the start includes reaction time, force application and the first two running steps. Start is the condition of the student's (runner) readiness to begin stand-up start and crouch start sprinting. The fundamentals of the start involve three commands which include your mark, set and go. Note that go can be a starter pistol or whistle.

On your mark command

The on your mark command is used when the runner/athlete comes to the starting line to begin the race.

- a. Stand behind start line, relaxed, power foot in front.
- b. Place toe of back foot behind the heel of front foot, about 20-30cm.
- c. Look up slightly, focusing 2 meters ahead. Set command.

Note: Not used in races longer than 400 m

On the set command the runner/athlete must become as still as possible.

- a. Bend front knee slightly about 120 degrees, placing weight on ball of front (power) foot.
- b. Hold arm opposite from front foot flexed in front of body.
- c. Hold other arm back, hand closed slightly past the hip.
- d. Stand as still as possible.

Go command sound of the starters' pistol or whistle

The go command is for the runner/athlete to start moving. The go command is usually created by the sound of a starter pistol or other device, such as a whistle.

- a. Drive back leg forward, leading with knee, swinging front arm back.
- c. Push strongly off ball of front (power)

foot, swinging back arm forward forcefully.

c. Stay low, using arms to drive body forward.

d. Each leg is driven powerfully until it is fully extended.

e. Vigorous arm action is maintaining balance, rhythm and relaxation.



Fig. 3.1.1 starting phase

Accelerating phase

The accelerating phase is achieved by driving or pushing with the drive leg. This requires a forward lean, which is directly proportional to amount of acceleration. This performance phase is the first of two links between the initial movements of the start and maximum velocity sprinting. The initial eight to ten steps represent this phase. The sprint mechanics of acceleration are very different from maximum velocity sprinting.

a. As drive leg is driving or pushing, free leg is also driving low and fast to place the foot under the body's center of gravity.

b. Heel recovery of drive leg is low coming out of the blocks.

c. With each step, speed increases until top speed is reached.

d. Each leg is driven powerfully until it is fully extended.

e. Vigorous arm action is maintaining balance, rhythm and relaxation.

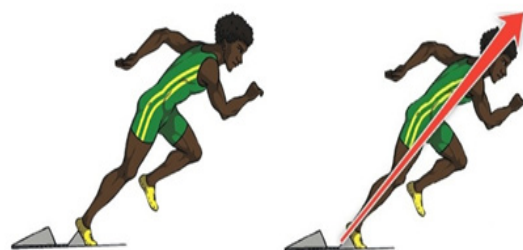

Fig. 3.1.2 Acceleration phase

Maintaining momentum phase

What some refer to as the deceleration phase, should be referred to as speed maintenance. The performance objective should be to maintain as much top speed as possible. Of course, it is likely that a gradual decline in velocity will occur due to various elements of fatigue. The maintaining momentum phase is achieved by combining basic mechanics with the speed attained in the accelerating phase.

a. Drive knees up so thigh is parallel (horizontal) to track.

b. High heel recovery is maintained as drive foot leaves ground.

c. Maintain tall posture, with slight forward body lean from ground, not from waist.

d. Swing arms forward and back vigorously, without rotating shoulders.

e. Keep feet flexed, toes up.



Fig 3.1.3 maintaining momentum Phase

Finish Phase

Many races have been lost or qualifying standards hardly missed because of the lack of finishing technique. Perfecting this skill can reduce a sprinter's time by that critical one.

a. While sprinting down the track, the athlete maintains good posture with normal stride action through finish line.

b. Taking the last stride, the athlete lunges forward and leans through finish line. Athlete should pretend that the finish is beyond where it really is to continue momentum



Fig. 3.1.4 Finishing phase

3.2.2 Basic relay techniques

Specific objectives

At the end of this lesson, you will be able to:

☞ Practice skills which enable to participate in relay run;

☞ practice the basic relay running techniques and,

☞ identify the basic relay sprinting rules.

Relays in athletics are the time when athletes get to come together as a team. Relay racing is the art of running with a baton and passing it from one teammate to the other, and making three exchanges with the fourth runner crossing the finish line with the baton.

Relay running is a team work, in which four runners participate in a competition. The purpose of the race is

to exchange the baton between four runners and having a result as one athlete is running in the race. The relay race originated in the United States of America, the first recorded relay place in athletics meeting at the University Pennsylvania in 1893. Since then it became the traditional climax of most athletic matches and championships.

The two very common relay sprint events are 4×100 meter relay and the 4×400 meter relay. The 4×100 m event is run strictly within the same lane on the track, meaning that the team collectively runs one complete circuit of the track. Teams in a 4×400 m event remain in their own lane until the runner of the second leg passes the first bend, at which point runners can leave their lanes and head towards the inner-most part of the circuit. For the second and third baton change overs, team mates must bring into line themselves in respect of their team position leading teams take the inner lanes while team mates of the slower teams must wait on the baton on outer lanes.

There is usually a labeled area where athletes must exchange the baton. The baton is a hollow cylinder of wood or plastic which was introduced in 1893. The baton must be passed inside the 20 meter passing zone. The baton weights 50g with 38 millimeters diameter and 25-30 centimeter length. A team may be disqualified if it fails to complete the change within the area, or if the team may be disqualified, if the team fails to complete the change within the area, or if the baton is dropped during the race.

A team may also be disqualified if its runners are deemed to have deliberately obstructed other competitors.

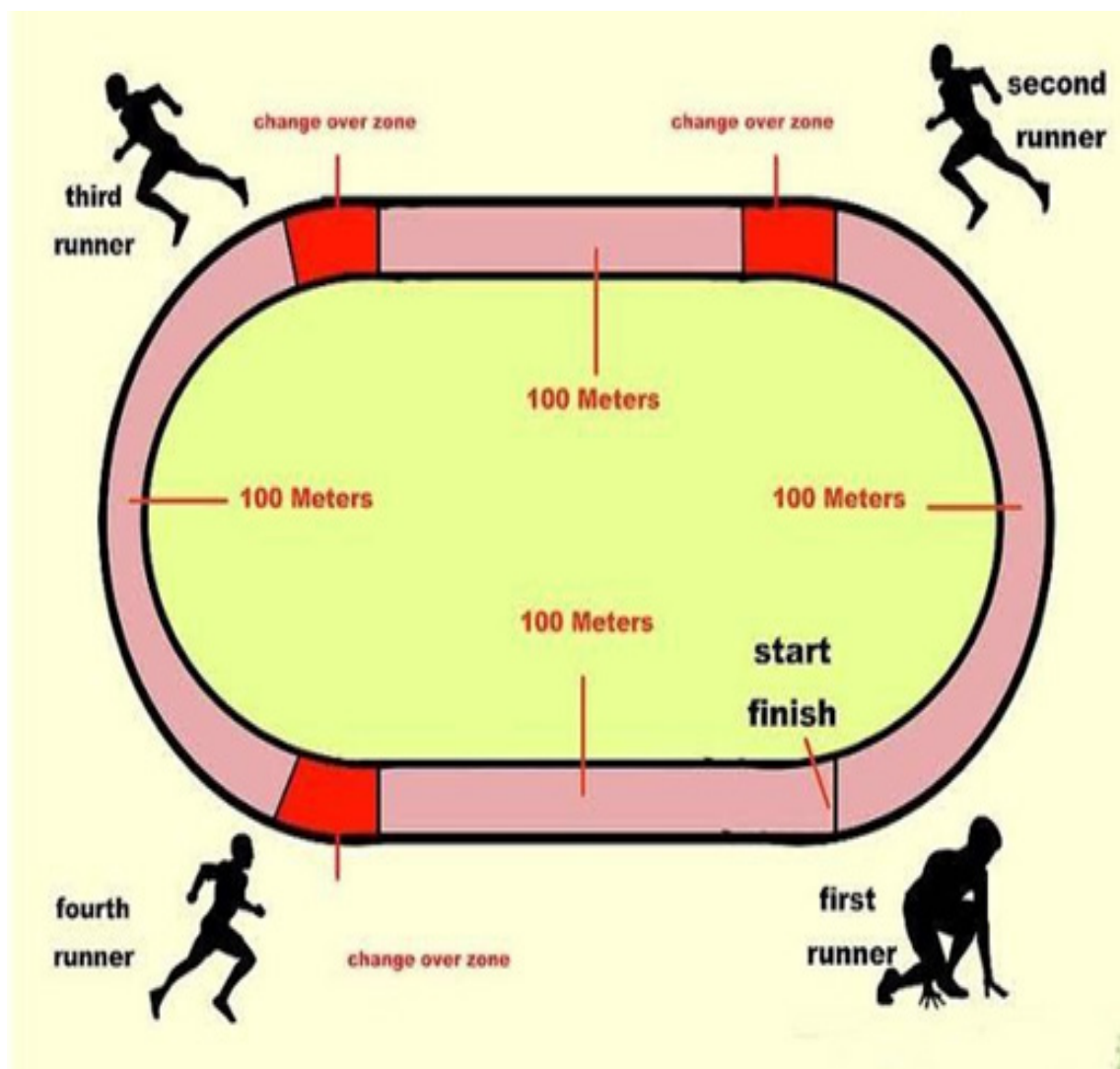

Fig. 3.2.1 Track of relay baton exchange zone

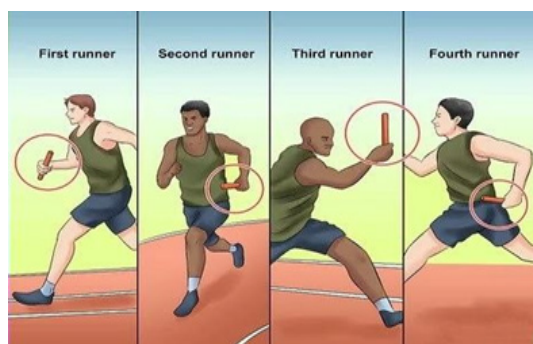

Fig. 3.2.2 Baton holding/ in relay race

Startup activity 3.2.2.1

1. What is the technique of the upward/upsweep baton exchange?
2. What is the technique of the downward/down-sweep baton exchange?

There are two ways used for baton exchange during relay race. These are upward/upsweep exchange and downward/down-sweep exchange.

The upward/upsweep baton exchange

is the baton carrier which passes the baton with an upward pushing motion. The baton is thrust as far as possible into the hand of the baton receiver. The baton receiver grips the baton between the V formed by the fingers and the thumb of the receiving hand which is positioned palm down.

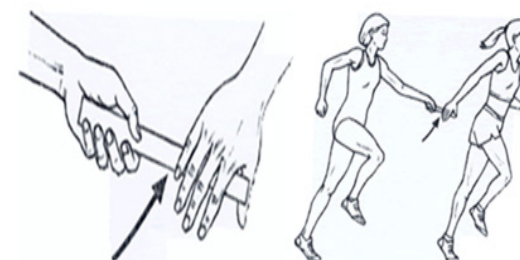

Fig. 3.2.2 upward/upsweep baton exchange

The downward/down-sweep baton exchange is the baton is placed “down” into the waiting runner’s palm. The waiting runner holds the arm with palm facing up, in a “V,” with the thumb positioned toward the body.

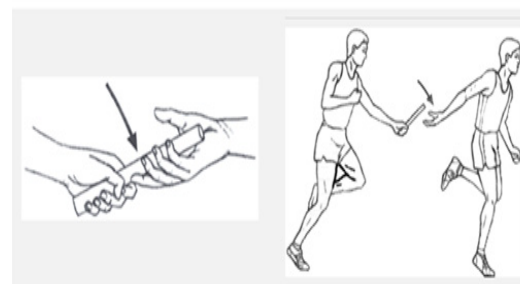

Fig. 3.2.3 Downward/down-sweep baton exchange

Activity 3.2.2.2

1. Practice downward and up-ward exchange of baton with your partners form stationary position.
2. Practice downward and up-ward techniques baton exchange with walking by giving sound signal to your receiver to extend his/her had backward.

3. Perform downward and up-ward techniques baton exchange with jogging by giving sound signal to your receiver to extend his/her had backward.
4. Practice downward and up-ward techniques baton exchange with running by giving sound signal to your receiver to extend his/her had backward.
5. Perform in pairs to demonstrate the call by the baton carrier and a pushing down ward action/exchange with the baton.
6. Perform in pairs to demonstrate upward baton exchange the receiver action of line of vision and acceleration once the baton carrier passes the line of baton exchange zone.

Unit summary

Ethiopia has enjoyed a rich tradition of producing some of the world’s fastest distance runners over the past decades. The country has had a healthy rivalry with East African neighbor Kenya and this has spurred each nation to achieve quicker times on both track and road.

The African athletics sport organizing body the Confederation of African Athletics (CAA) was established in 1973. The CAA now a days has 54 member countries and headquarters in Dakar, Senegal. The CAA current president is known as Hamad Kalkaba Malboum from Cameroon.

Abebe Bikila from Ethiopia was the first black African man to win Olympic gold medal. In the 1970s, Africa gave the world several great champions and world record setters like Uganda’s 400 meter hurdler John Akii-Bua and Tanzania’s 1500 m runner and steeplechaser Filbert Bayi.

☞ The 1992 Olympics in Barcelona was 10,000 meter Women race in Barcelona, a titanic battle in which Ethiopia's De rartu Tulu prevailed over South Africa's Elana Meyer. Derartu made history to become the first black African woman to win Olympic gold.

☞ Track event is a sport comprising various competitive athletic contests based on running individual sports with athletes challenging each other to decide a single victor. The racing events are won by the athlete with the fastest time.

☞ Sprinting events focus on athletes reaching and sustaining their quickest possible running speed. Sprinting race category includes distances up to 400 meters. Three sprinting events are currently held at the Olympics and outdoor World Championships are 100 meters (m), 200 m, and 400 m.

☞ Basic sprint techniques classified into four phases. These are start, acceleration, maintaining momentum and the finish.

☞ Relay races are the track event in which a team of runners directly compete against other teams. Typically, a team is made up of four runners of the same sex.

☞ runner completes their specified distance before handing over a baton to a team mate,

☞ Each runner completes their specified distance before handing over a baton to a team mate, who then begins their leg upon receiving the baton.

☞ The two very common relay sprint events are 4×100 meter relay and the 4×400 meter relay. The baton must be passed inside the 20 meter passing zone. The baton is weights 50 grams with 38 millimeter diameter and 25-30 centimeter length.

☞ There are two ways used for baton exchange during relay race. These are upward/up-sweep exchange and downward/down-sweep exchange.

☞ The fundamentals of the start of sprint involve three commands are on your mark, set and go. Note that go can be a starter pistol or whistle.

Unit review questions

I. Matching Item

Column A	Column B
1. Sprint run	A. Forward lean
2. Starting phase	B. Set
3. Relay race	C. 200 m
4. Accelerating phase	D. 100 x 4 m
	E. 4 x 100 m

II. Multiple Items

1. One of the following is the first women black African who won Olympic gold medal in 10,000 meter race athletics.

A) Maria Mutola

B) Derartu Tulu

C) Elana Meyer

D) Hassiba Boulmerka

2. The first command given by judges for sprinting run is _____.

2. The first command given by judges for sprinting run is _____.

A) On your marks

B) Stand up

C) Set

D) Fire the Pistol

III. Discussion questions

1. Discuss the similarity and difference between short distance run and relay sprint events.

2. Are there different commands given to start short distance run and relay sprint events? Mention the types of commands.

UNIT FOUR FOOTBALL

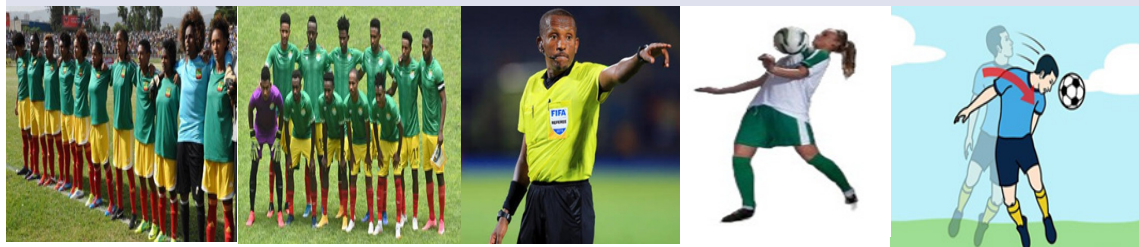

Introduction

The most popular and interesting sport in terms of spectators and participation, in the world is football. Students, it is not unfamiliar to see the majority of youths in Ethiopia spending their time either watching football game in the playground or through TV and even playing football in their surroundings. From this, it is possible to infer that football is the dominant sport in the world and in our country Ethiopia too. Therefore, students, this unit is very important and interesting as you will learn about the brief history, basic rules, and fundamental skills of the most popular sport in the world and in our country Ethiopia as well.

Unit objectives

At the end of this unit, you will be able to:

- ☞ analyse the history of football;
- ☞ recognize major events in football history;
- ☞ know the basic rules of football;
- ☞ develop the correct skills in a football game and,
- ☞ enjoy positive interpersonal relationship.

Unit Contents

- 4.1. Brief history of football
- 4.2. Rules of football
- 4.3. Skills of football
- Unit summary
- Review questions

KEY WORDS:

Football, Rules, Players
Referee, Off-side, Throw in,
Control, Heading, Scoring

4.1 Brief history of football

4.1.1. World history of football

Specific objectives

At the end of this lesson, you will be able to:

- ☞ mention when and where football was invented and,
- ☞ analyse how football was emerged in the world.

Start-up Activity 4.1.1.1

1. What do you know about football?
2. Are you interested to play football? Why?
3. What is the benefit of learning football history? Please reflect to the class.

In the world, records of football were once the very earliest structure of the game. It started as an exercising for an army guide in China courting lower back to 206 B.C. to 220 A.D.. The ancestor of football is Ts'u Chu who used to be from the Han Dynasty.

It was once believed that, comparable structure of this game, known as kemari, was once started about 500-600 years after the introduction via Ts'u Chu, in Japan, which in flip was once observed through chuk-guk in Korea.



Figure 4.3 Ancient Japanese game

The Ancient Greek Episkyros and the Roman Harpastum had been later performed with a smaller ball through two groups on a rectangular area marked through boundary traces and a centerline.

Football grew in reputation in Europe in 1314. After a sure duration of time, in 1365, King Edward III of England genuinely made the sport punishable by means of regulation due to the fact it distracted troopers from practicing extra beneficial army disciplines, mainly archery.



Figure 4.4 Ancient Greek's game

The sport in England was once performed between huge teams, from time to time entire villages, on a massive field, and the ball should be thrown, kicked, or carried in the direction of the opponent's goal. There have been very few guidelines and games which were frequently wild and rough. The football game used to be persistently banned through the authorities because of the violence and accidents it caused.

In nineteenth century, the current sport soccer was first developed in England. The Football Association used to be set up in 1863 and the 'Laws of the Game' have been drawn up in the identical year.

The International Football Association Board (IFAB) was once fashioned through the year 1882. This employer nonetheless oversees the regulations of the game. Then ,after a period of time, in1904, FIFA (Federation Internationale de Football Association) was once situated to run global competitions. FIFA runs the World Cup, as well as regional competitions such as the European and Asian Cups.

In the records of football, school soccer grew to become the custom, especially in the well-known public school, at the opening of the nineteenth century. But the guidelines had been nevertheless extraordinarily free and easy, with nongeneral structure of the game.



Figure 4.5 Character house School-1863

In 1863, the first Football Association (FA) used to be established in Great Britain (including; Wales, Scotland, Northern & Ireland).

FA shortly gives the first laws of soccer affiliation in 1863 and following that the game of current football began. FA geared up knock-out competition in 1872 "The Wanderers of London" received the first FA cup through defeating "The Royal Engineers of London".



Figure 4.6 Introduction of modern football

In 1883, the four British associations settle on a uniform code & form the International Football Association Board (IFBA).

The 1896 Olympics in Athens, soccer used to be no longer protected as a medal sport. However, demonstration of the game used to be played. In the 1904 Olympic, in St. Louis, soccer was once added as a reputable Olympic sport for the first time. Canada gained the gold medals. Only three groups participated at this time.

Then FIFA (Federation Internationale de Football Association) was established in May 21, 1904 with the

coordination of representatives from France, Belgium, Holland, Denmark, Sweden, Switzerland and Spain to run global competitions.

By 1906 a consensus was reached between the FA and FIFA. Then, FIFA remained the solely law making body. However, every country that made up Great Britain grew to be a separate member of FIFA, permitting everyone to compete personally in any event prepared with the aid of FIFA. These nations are England, Scotland, Wales, and Ireland.

Activity 4.1.1.2

What was the role of FIFA on football development?

The first World Cup game was once equipped through FIFA in Uruguay in 1930 and the same country won the first world cup. The World Cup held every four years prepared with the help of FIFA is nevertheless the most prepared competition that holds the interest of all peoples in the current world.

Nowadays, there are greater than 209 nations who are affiliated to FIFA, making it the greatest and most influential sport body in the entire world.

In 1954, some other confederation through the equal Union of European Football Association (UEFA) used to be established.

Activity 4.1.1.3

1. When and where was football started?
2. When and where was FIFA established?
3. List some of the countries which establish FIFA.

Table 4.1 World cup host & winner countries by year

YEAR	HOST	CHAMPION	YEAR	HOST	CHAMPION
2022	Qatar	?	1978	Argentina	Argentina
2018	Russia	France	1974	West Germany	West Germany
2014	Brazil	Germany	1970	Mexico	Brazil
2010	South Africa	Spain	1966	England	England
2006	Germany	Italy	1962	Chile	Brazil
2002	South Korea, Japan	Brazil	1958	Sweden	Brazil
1998	France	France	1954	Switzerland	West Germany
1994	United States	Brazil	1950	Brazil	Uruguay
1990	Italy	West Germany	1938	France	Italy
1986	Mexico	Argentina	1934	Italy	Italy
1982	Spain	Italy	1930	Uruguay	Uruguay

4.1.2. African football history

Specific objectives

At the end of this lesson, you will be able to:

- ☞ mention when and where African Football Federation (CAF) was established and,
- ☞ differentiate some members of CAF who contribute a lot on the establishment of the organization.

Start-up activity 4.1.2.1

1. Can you list some African footballer?
2. Name your favorites football players from Africa.

Football was once first delivered to Africa by way of Europeans in the late nineteenth century. The football game was performed in 1862, at least the first recorded game on the African continent. By 1882, the game develops in the course of the continent, through missionaries, railway employees and the military.

In 1882, consequently, the first and longest-lasting African football clubs founded, particularly the Savages FC from South Africa and Gezira SC from Egypt. These two are the oldest soccer clubs in Africa. In 1890, Alexandria FC from Egypt and in 1897 CAL Oran from Algeria were founded. The improvement of soccer was once so quickly in the first three years of 20th c in Africa where nations like Central Africa had been also included.



Figure 4.7 A team from African Cup of Nations

Before the CAF was founded, soccer in Africa used to be flawed, teenagers had been exploited and witch physicians had a massive section earlier than the game. Animal sacrifices were made and a number of magic rituals were carried out prior to a game.

Confederation of African Football (CAF), the governing organization of African football, was situated in 1957, in Khartoum, Sudan. The four founding countries were Sudan, Egypt, South Africa and Ethiopia.

The first Africa Cup of Nations was held in February, 1957, Khartoum, Sudan. The participant nations were Sudan, Egypt, and Ethiopia. South Africa initially was scheduled to compete, however disqualified due to the apartheid cover policies of the authorities then in power. Then, the game used to be held between these three countries, Ethiopia, Sudan, and Egypt. Egypt used to be topped as the first continental champion after defeating Sudan, which hosted the champion in the semi-final and received Ethiopia 4-0 in the final.

Activity 4.1.2.2

Students, be in group and describe the contribution of CAF in the development of African football and present your result to the whole class.

Women's football in Africa hasn't had the identical destiny as the men's football have had. It started in Nigeria. Senegal and Nigeria performed the most of any different country when it comes to women's football. Nigeria even sent their country national football team to the 1991 Women's World Cup.

In 1991, the Women's Cup of Nations used to be mounted with the help of the CAF and Nigeria, to no one's surprise, received the Cup eleven times, out of thirteen. Equatorial Guinea received the closing two tournaments. It is a biennial match however was no longer biennial till 1998. It turned out to be a qualifying event for the Women's World Cup and saw that 1993.



Figure 4. 8 Nigerian Team-The winner of 2018 Women's Africa Cup of Nations

Football in Africa had to go through different challenges such as the influence of doctors who influenced more than the coaches to attain its modern football championship.

Today, both men's and women's Africa Cup of Nations are held every two years and fans from Africa have what to look forward to, every season and every two years.

Activity 4.1.2.3

1. When and where was CAF established?
2. List some of the countries which established CAF?

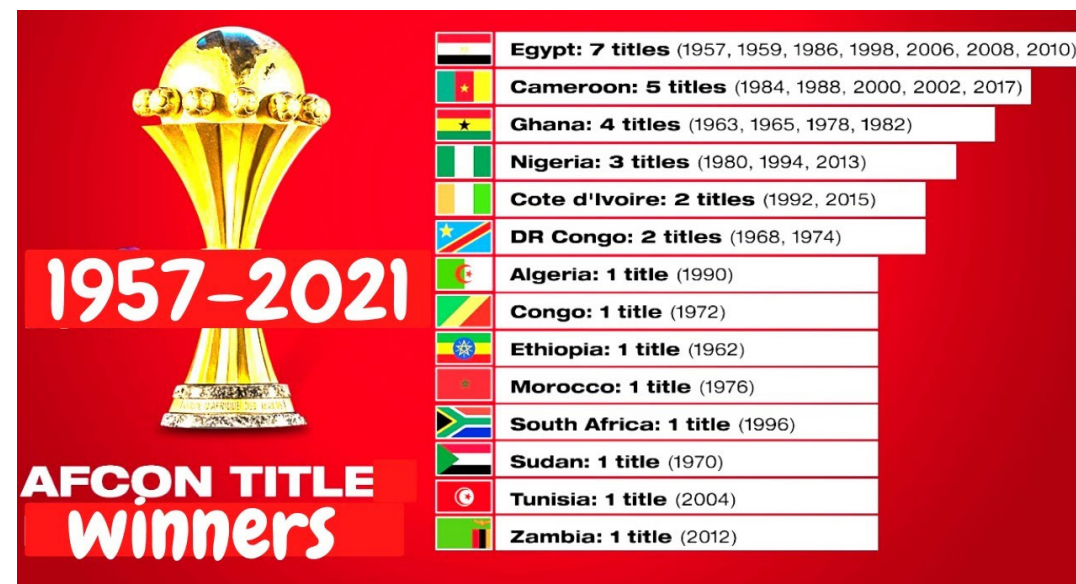

Figure 4. 9 African cup of Nation Winners by Country

4.1.3 Ethiopian football history

Specific objectives

At the end of this lesson, you will be able to:

- ☞ mention when Ethiopian Football Federation was established and,
- ☞ name those who contributed for its establishment.

Start-up activity 4.1.3.1

1. Can you list some Ethiopian footballers?
2. Name your favorite football players from Ethiopia.

Football has been the most famous and surprisingly practiced activity in Ethiopia. Documents confirmed that football was once being performed in Ethiopia with the help of foreigners, who originated from America, India, Greek and Italia. They fashioned locality and held tournaments at "Jan Hoy Meda".

The game activity observed its way to Teferi Mekonnen and Menlik II High schools. The opposition in the schools made football to be chosen as the most desired one.

There have been indicators that football clubs existed at the Teferi Mekonnen School as early as 1927. The contestants remained foreigners such as Armenians and Greeks, who had been determined refugee repute through Ethiopia. The first football group in Ethiopia used to be "Addis Ababa Select Team", formed in 1935 (1927 E.C), via a team of Ethiopians and Armenians.

In December 1935, the first equipped football club in Ethiopia "St. George Football Club" used to be established with Yidnekachew Tessema, as one of the founding members, who is considered as the Father of Ethiopian football.



Figure 4.10 Yidnekachew Tessema

In 1943 (1935 E.C), for the first time, in the presence of Emperor Haile Selase, a football match was held between five teams namely St. George, British Military Mission(BMM), Greek, Armenia, and Fortitude(Italian team). After the match, three teams BMM, St. George and Fortitude finished the match respectively.

In the same year, St. George played against the Italian team Fortitude and won 4-1.



Figure 4.11 Ethiopian St. George Team

The Ethiopian Football Federation (EFF) was founded in 1943. The EFF is affiliated to FIFA in 1953 and to the Confederation of African Football in 1957.

Ethiopia was one of the pioneers of the Africa Cup of Nations and was one of solely three groups to enter the inaugural 1957 tournament, ending as runners-up to Egypt. They additionally existed at the 1959 match as

hosts of the 1962 event and led by means of help goal scorer Mengistu Worku. On that tournament, Ethiopia defeated Tunisia and the United Arab Republic (Egypt) to be topped African champions for the solely time in their history.

Activity 4.1.3.2 ?

What is the contribution of EFF on the development of football in Ethiopia?

Ethiopia had to wait till 2013 when the country was once certified for the final match after a 31-years of absence. Fortunately, Ethiopia once more came back to the Africa Cup of Nations (AFCON) after an absence for eight years in 2021.

Ethiopia is additionally participants of the Council for East and Central Africa Football Associations (CECAFA) and has taken section in competitions. First Ethiopia received the CECAFA Cup in 1987 as hosts and repeated the identical triumph in 2001 and 2004 and then brought a fourth title in Rwanda in 2005.

Ethiopia was once the host country of the forty first Council for East and Central Africa Football Associations (CECAFA) Cup in July, 18-31, 2021 in Bahirdar.

Eleven football teams were participated on this competition. The followings are some of the competition organized by Ethiopian Football Federation.

Women competition: currently, in Ethiopia there is only one Women Premier League competition which involves female players.

Women premier league

In this competition there are 20 teams participating by being divided into

two groups. Men competition: in this case, in Ethiopia there are different types of competition. Some of these are:

Premier league:

This competition is the highest competition in the country in which clubs compete to be winner of the country and represent the country in African club competition. Based on the establishment and the current status of the clubs, we can see the pictures of Ethiopia Saint George and Fasil Kenema respectively.



Figure 4.12 (a) St. George FC



Figure 4.12 (b) Fasil Kenema FC (winner of 2020/21 Premier League)

Higher league:

This competition is the second division of football in Ethiopia. It operates on a system of promotion and system of promotion and relegation along with the Ethiopian Premier League (first division) and the Ethiopian First League (third division).

First league

This competition is established for clubs of different regional representatives to

compete in the competition to pass to the higher league.

Activity: 4.1.3.3 ?

1. When were EFF established?
2. Can you mention which team started playing football in our country?
3. List out the type of football competition in Ethiopian.

4.2. Rules of Football

Specific objectives

At the end of this lesson, you will be able to:

- ☞ differentiate the types of football rules in a game and,
- ☞ apply the basic rules of football while playing small sided games.

Start-up activity 4.2.1 ?

1. Did you have rules while you are playing football?
2. What are your rules to play football?

4.2.1. The playing area

The playing area should be a thoroughly natural or, if competition rules permit, a wholly artificial playing surface except where competition rules permit an integrated combination of artificial and natural materials (hybrid system). The colour of artificial surfaces must be green.

The field of play should be rectangular and marked with non-stop traces which should no longer be harmful; artificial playing floor fabric may also be used for the subject markings on natural fields if it is now not harmful. These traces belong to the areas of which they are boundaries.

Table 4.2 Dimensions of football field

Age Grouping	Measurement in meter			
	Pitch length		Pitch width	
	Maximum	Minmum	Maximum	Minimum
UNDER 7 TO 8-YEARS-OLD	45.75M	27.45M	27.45M	18.3M
UNDER 9 TO 10-YEARS-OLD	54.9M	45.75M	36.6M	27.45M
UNDER 11 TO 12-YEARS-OLD	73.85M	54.9M	50.77M	42M
UNDER 13 TO 14-YEARS-OLD	73.85M	64.62M	56M	42M
UNDER 15 TO 16-YEARS-OLD	82M	70M	56M	42M
UNDER 17,18-YEARS-OLD AND	120M	90M	90M	45M

The playing area of football

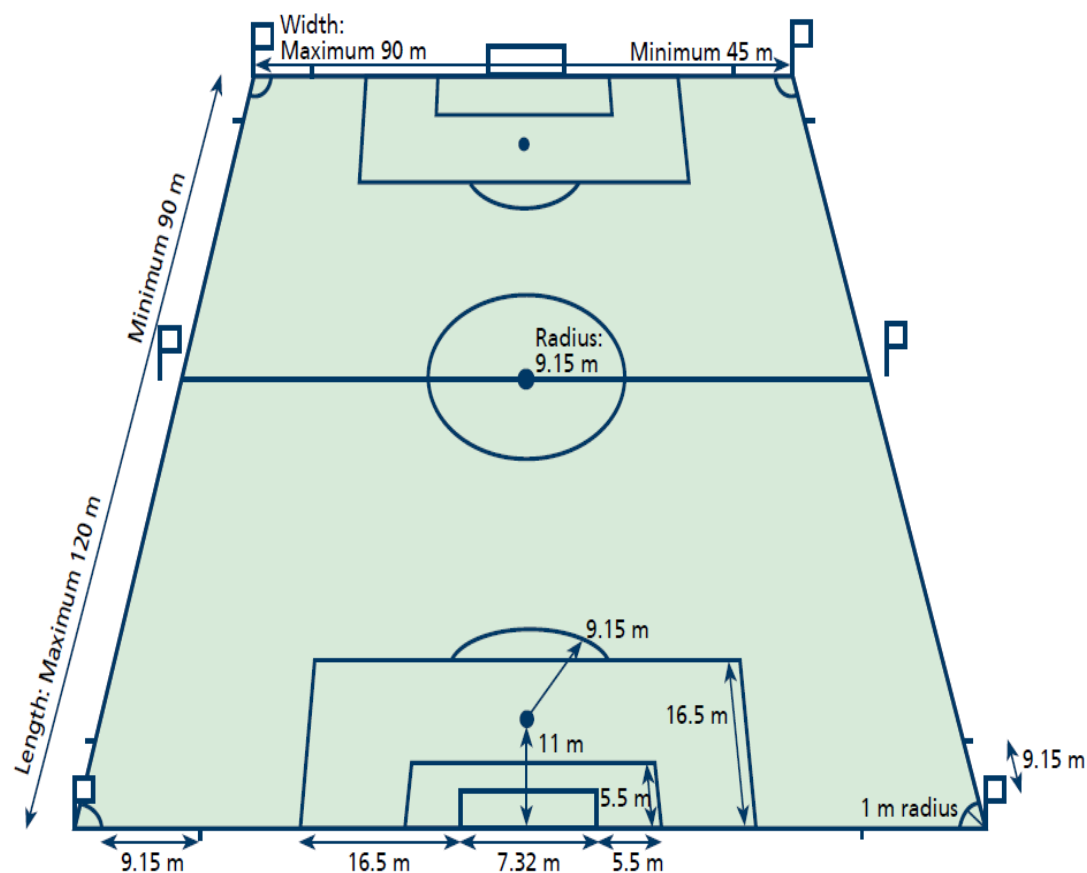

Figure 4.13 The playing area of football field

4.2.2. The players

In modern-day soccer game is performed by using two teams, each group with having at most of eleven players; one need to be the goalkeeper. A game may additionally now not begin or

proceed if both teams have fewer than seven players.

If a group has fewer than seven gamers due to the fact one or greater gamers have intentionally left the subject of play, the referee is no longer obliged to

give up play and the benefit might also be played, however the game should no longer resume after the ball has long gone out of play if a group does no longer have the minimal quantity of seven players

The number of substitutes, which may be used in any match played in an official competition, be it the confederation or the national football association will be determined by FIFA. It is up to a maximum of five except for men's and women's competitions involving the 1st teams of clubs in the top division or senior 'A' international teams, where the maximum is three substitutes.

4.2.3. The referee

There are a total of nine referees to be participated in one match. These are one main referee, two assistant referees, fourth official, two additional assistant referees, reserve assistant referee, video assistant referee (VAR) and at least one assistant (VAR (AVAR)) may be appointed to matches.

Each match is controlled by a main referee who has full authority to enforce the Laws of the Game in connection with the match. Decisions will be made to the best of the referee's ability according to the Laws of the Game and the "spirit of the game" and will be based on the opinion of the referee who has the discretion to take appropriate action within the framework of the Laws of the Game.

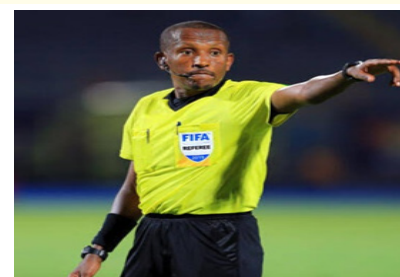

Figure 4.14 Football Main Referee

Activity 4.2.2

1. Can you list some rules of football?
2. How many players are expected to start the game in football?

The duties of the two linesmen are controlling the whole of the ball leaves the field of play and which team is entitled to a corner kick, goal kick or throw-in. A player in an offside position may be penalised. A substitution is requested. At penalty kicks, the goalkeeper moves off the goal line before the ball is kicked and if the ball crosses the line. If additional assistant referees have been appointed the assistant referee takes a position in line with the penalty mark. The assistant referee's assistance also includes monitoring the substitution procedure. The assistant referee may enter the field of play to help control the 9.15m (10 yards) distance.

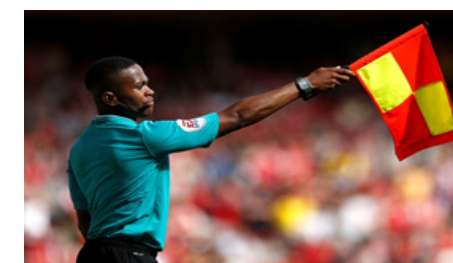

Figure 4.15 Football Assistant Referee

The fourth official's assistance also includes: supervising the substitution procedure, checking a player's/substitute's equipment, the re-entry of a player following a signal/approval from the referee, supervising the replacement balls, indicating the minimum amount of additional time the referee intends to play at the end of each half.

A video assistant referee (VAR) is a match official who may assist the referee to make a decision using

replay footage only for a 'clear and obvious error' or 'serious missed incident' relating to a goal/no goal, penalty/no penalty, direct red card (not a second caution) or a case of mistaken identity when the referee cautions or sends off the wrong player of the offending team, half (including extra time), informing the referee of irresponsible behaviour by any technical area occupant.



Figure 4.16 Referee Reviewing VAR

4.2.4. Duration of the game

A match lasts for two equal halves of 45 minutes, which is 90 minutes to play the game. There is also 15 minutes half-time break between 90 minutes of each game. Time loss allowance is made by the referee in each half for all time lost in that half through: substitutions, assessment and/or removal of injured players, wasting time, disciplinary sanctions, medical stoppages permitted by competition rules, e.g. 'drink s' breaks (which should not exceed one minute) and 'cooling' breaks (ninety seconds to three minutes) delays relating to VAR 'checks' and 'reviews', any other cause, including any significant delay to a restart (e.g. goal celebrations)

4.2.5. Ball in and ball out

The ball is in play at all other times

when it touches a match official and when it rebounds off a goalpost, crossbar or corner flag post and remains on the field of play.

The ball is out of play when:

- it has wholly passed over the goal line or touchline on the ground or in the air, play has been stopped by the referee;
- it touches a match official, remains on the field of play and: a team starts a promising attack or the ball goes directly into the goal or the team in possession of the ball changes. In all these cases, play is restarted with a dropped ball.

4.2.6. Scoring

A goal is scored when the whole of the ball passes over the goal line, between the goalposts and under the crossbar, provided that no offence has been committed by the team scoring the goal. If the goalkeeper throws the ball directly into the opponents' goal, a goal kick is awarded. If a referee signals a goal before the ball has passed wholly over the goal line, play is restarted with a dropped ball.

4.2.7. off-side

A player is in an offside position if:

- Any part of the head, body or feet is in the opponents' half (excluding the halfway line) and
- Any part of the head, body or feet is nearer to the opponents' goal line than both the ball and the second-last opponent. The hands and arms of all players, including the goalkeepers, are not considered.

A player is not in an offside position if level with the:

- second-last opponent or last two opponents

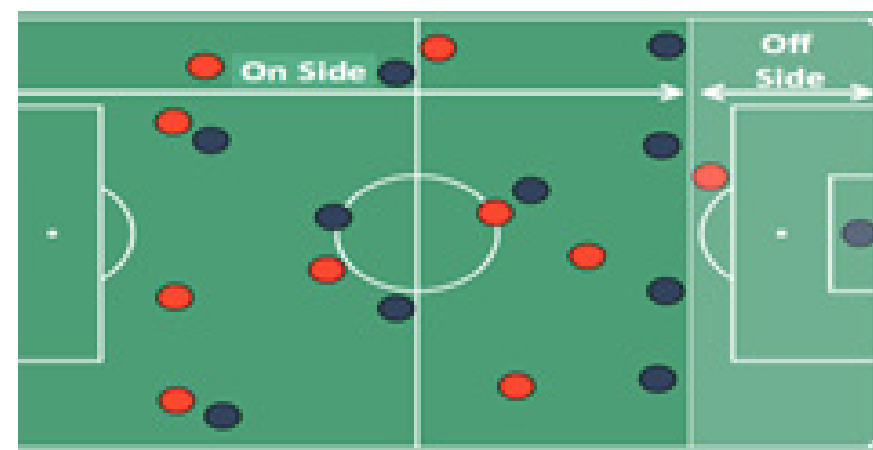

Figure 4.17 Offside Position

4.2.8. Throw-in

A throw-in is awarded to the opponent of the player who last touched the ball when the whole of the ball passes over the touchline, on the ground or in the air.

A goal cannot be scored directly from a throw-in:

- If the ball enters the opponents' goal – a goal kick is awarded.
- If the ball enters the thrower's goal – a corner kick is awarded.



Figure 4.18 Throw-in

4.2.9. Corner kick

A corner kick is awarded when the whole of the ball passes over the goal line, on the ground or in the air, having

touched a player of the defending team, and a goal is not scored. A goal may be scored directly from a corner kick, but only against the opposing team; if the ball directly enters the kicker's goal, a corner kick is awarded to the opponents.



Figure 4.19 Corner Kick

Activity 4.2.3 ?

1. Students, as a group, organize and lead football game between two teams. Do not forget that the game will be managed by the group members. Then, reflect to the class how your group manages the game and what was your role.
2. Can you mention some rules of football?
3. List the standard dimensions of football.

4.3. Skills of Football

Specific objectives

At the end of this lesson, you will be able to:

- ☞ mention the type of football skills;
- ☞ show respectful communication skills;
- ☞ demonstrate chest control skills;
- ☞ perform heading skills;
- ☞ demonstrate responsibility and,
- ☞ accept ideas from others.

Start-up activity 4.3.1

1. Students, be in pair or group and tell to each other the skills of football.
2. Demonstrate some skills of football.

Dear students, when you were in grade eight you thought the fundamental skills of football, like passing, receiving, kicking, dribbling, and other skills which are very important for playing football. In this lesson we will learn some skills like controlling and heading using your different part of the body.

4.3.1. Chest control

Specific objectives

At the end of this lesson, you will be able to:

- ☞ describe chest control skill of football;
- ☞ practice chest control activates in football and,
- ☞ demonstrate chest control skills at least once from the three trials.

In order to keep possession in football it is critical that players master the art of maintaining possession. To maintain the game, performing proper skills while playing the game is fundamental. One of these skills is controlling the ball with different part of the body while playing the game.



Figure 4.20-a) Chest Control

Controlling the ball using your chest is one way to control a ball out of the air. There are multiple styles, reasons and ways to control a soccer ball using your chest. Today we are learning the basic style to control a ball using your chest.

Note:

Female students, while practicing chest control, use softball to be comfortable and safe!!

The followings are some of the steps that you are going to use to develop chest control.

- a. The body should be positioned behind the flight of the ball.

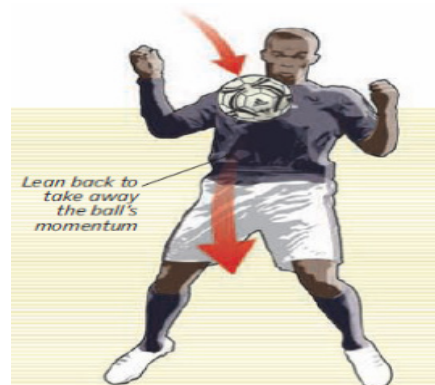

Figure 4.20-b) Chest Control

- b. Knees should be slightly bent.
- c. Elbows should be held away from the body and hands clear of the chest surface.

Activity 4.3.2

Students, make group and practice the above three steps by arranging your groups in different formation on the field of play.

- d. Keep the shoulders and hips square to the ball.
- e. Lean back slightly from the trunk of your body to absorb the pace of the ball.
- f. Withdraw the chest immediately as the ball is touched.

Activity 4.3.3

Students, make group and practice the above three steps by arranging your groups in row formation on the field of play.

Female students, please consider safety measures!!

- g. Slightly concave your back to cushion the ball.
- h. Touch the ball down to your feet.
- i. Lean forward over the ball.
- j. Move first touch to space and accelerate.

Activity 4.3.4

Students make group and practice the above four steps by arranging your groups in row formation with having a distance of 3-4m between rows on the field of play.

Female students, please consider safety measures while practicing this activity!

4.3.1.1. Mini game using chest control

Specific objectives

At the end of this lesson, you will be able to:

- ☞ explain how to control the football on the chest;
- ☞ value chest control activate of football and,
- ☞ apply chest control skills whenever necessary in the game situation.

One of the mechanisms to master the skills of football is practicing in a

An excellent way to practice these skills is via a game of “head tennis” played over modified volleyball net; you must keep the ball from touching the ground, and return it over the net by using your feet and chest. The more frequently you play this enjoyable game, the better your skills will become.

Students, you can make a circle and put one of your friends in the middle then play passing game using chest and foot pass. Try these activities for several times by changing the middle player as much as possible.

4.3.2. Heading

Specific objectives

At the end of this lesson, you will be able to:

- ☞ explain how to kick the ball using head;
- ☞ perform heading activity and,
- ☞ apply heading skills in the game situations.

Heading the ball is counter intuitive for any young players learning the game, because they think it will hurt. However, it is an essential skill to master because, on an average, the ball is in the air for 30 per cent of the match time.

Start-up activity 4.3.5

1. In which part of your body you score the goal in football game?
2. Demonstrate some skills of scoring the goal in football.

Heading is extremely valuable. Players that head the ball well score more goals, clear the ball, and help their teammates win possession in the midfield. Therefore, players should give special emphasis to have skills of heading in football.

Note: Students, while practicing heading, use softball to feel comfortable and be safe!!

4.3.2.1 Side /Glancing/ heading

When a player is performing a football side header, the head will be faced in the direction of where they want the soccer ball to go. The goal of this header is to change the direction of the soccer ball,



Figure 4. 21 Side Heading

To perform the correct heading in the game situation, you need to practice the procedures of heading step by step. Students, there are different steps design by different coaches and physical education teachers to develop the correct heading techniques. For the time being, please follow these steps while you are kicking the ball using your head:

- Keep your eyes on the ball.
- Drive-through.
- Attacking the ball using your body.

Activity 4.3.6 (practical activity)

- Students, arrange your groups in different formation, then practice the above three steps in your groups.

Students, please consider safety measures!!

- Connect with the ball using your forehead.
- To shoot, head the ball towards the ground.

For a defender, get under the ball to get height and distance.

Activity 4.3.7

Students, arrange your groups in different formation. Then practice the above three steps in your groups.

Students, please consider safety measures!!

4.3.2.2. Front/standard/ heading

In football, there are different ways to kick or score the ball in the game situation. Heading is one of those techniques which players frequently use in the game. Students, first it is important for football players to learn how to approach the football ball and get a clean, powerful hit when heading the ball. During a basic football header, players have to make sure the shoulders stay level and balanced so that the forward head swing is controlled.

This heading is used for passing and attempts on goal. It is made with the forehead as this provides the most power and accuracy, and doesn't hurt, unlike heading with the top of your head. To get power on a header, bend your knees and arch your back as you jump for the ball, turning yourself into the shape of a bow. Tilt your head back initially, and then bring it forward rapidly using your neck muscles.



Figure 4. 22 Front Heading

Students, please follow these steps while you are kicking the ball using your head;

- Keep your eyes on the ball.
- Drive-through.
- Attacking the ball using your body.
- Connect with the ball using your forehead.
- To shoot, head the ball towards the ground.
- For a defender, get under the ball to get height and distance.

4.3.2.3. Mini game using heading

Specific objectives

At the end of this lesson, you will be able to:

- demonstrate how to kick the football on the head;
- value heading activity of football and,
- apply heading skills whenever necessary in the game situation.

Students, mini games are very much important to make you familiarize with the appropriate skills of heading in football. You may be playing in your environment different types of game using your head. Here you will try to see some mini games which will have a great impact on your heading skill development.

Students, while playing this game, consider safety measures and use appropriate ball (softball).

Students will be in pairs or group with a size of 8 by 4 metre area marked out with markers. Players take it in turns to head the ball over their partners' goal line by pulling the ball back and using their own momentum to head the ball. The players attempting to stop the ball can use their hands or dive if necessary.

They then throw the ball back and each player takes ten consecutive headers. Get the players to keep score and then see who the winner is at the end of the drill.

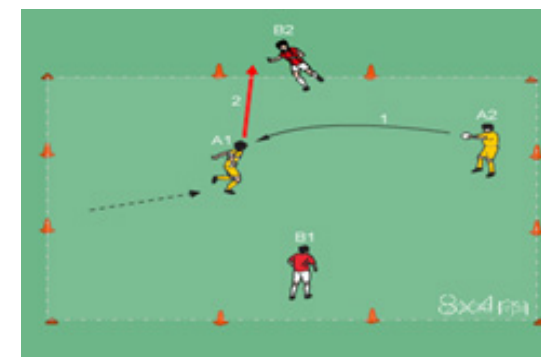

Figure 4.23 Positions for Mini Game Using Heading

Students, take the above mini game as example. Now, be in pair or in group as you like and try to design your own mini game using heading. Then practice it as much as possible. Do not forget to use safety measures while practicing this activity!

4.3.2.4. Modified game related to football

Students, you are going to learn those skills of football like chest control and heading with a modified football game with your friends. You may be selected and assigned by your group or your teacher in different group and try to play with the opponent groups using a modified football game. While playing this game, please consider safety measures!.

The modification of the game might be the rules of the game of football. Another modified game might be you have one player stand in the middle of two others, who each have a ball. The outside players take turns tossing the ball gently for the middle player

to head it back to them. The middle player must head one ball, spin around and head the other ball, then back again.

Female students, while playing this game, please consider safety measures! Continue for a given number of headers, say 10 to 20, and then switch the player in the middle. Students, this kind of game will create a good opportunity to develop your fundamental skills of football.

The last modified game is whole skill game which means the students make in group of four or six and play the football game by modifying rules and playing area using all skills of football which are necessary to play and score the ball in the game.

Students, based on the above modified games, now, you are requested to create and design modified game in your group. Each student has to play their own role while creating the game. Then demonstrate to the whole class.

Do not forget to use safety measures while practicing this activity!

Unit Summary

☞ Football had a long history. It was believed that the game began in China, Japan, and India. But the modern football began in England.

☞ FIFA (Federation Internationale de Football Association) was founded in May 21, 1904.

☞ Football was first introduced to Africa by Europeans in the late 19th century. The game was played in 1862, at least the first recorded game on the African continent.

☞ Confederation of African Football (CAF), the governing body of African

☞ The four founding members of CAF were Sudan, Egypt, South Africa and Ethiopia.

☞ The Women's Cup of Nations was established by the CAF in 1991.

☞ Football was first introduced in Ethiopia by foreigners.

☞ St. George was the first organized football club in Ethiopia. It was established in 1935 by a group of Ethiopian and Armenians.

☞ In 1943, the Ethiopian Football Federation was founded.

☞ In Ethiopia, there are different types of competition which are organized by Ethiopian Football Federation, like premier league, higher league, super league and others.

☞ Football has many rules which are vital for players to play the game. Some of the rules are the playing area, the number of referees, off-side position, corner kick, duration of the game, ball in and out, throw in and others.

☞ Every player should know and apply the rules of the game while they play football.

☞ Chest control in football is very important and fundamental. When you play football game, if the ball comes from air above your head, you will have a chance to control the ball using your chest and then you can pass to your partners or you can kick to score goals.

Unit Review Question

I. Read the following questions and answer properly.

1. Mention the countries which won African Cup of Nation.

2. Which club was considered as the first football club in our country?

3. List out some competition types that are organized by Ethiopian Football Federation.

4. What is the importance of having football rules?

5. Mention some rules of football.

6. Illustrate the appropriate football playing area with dimension for international competition.

7. Mention and demonstrate some skills which are very vital for playing football.

8. Demonstrate and perform with your friends how to control the air ball using your chest.

9. Demonstrate appropriate techniques of heading the ball using different part of your head.

UNIT FIVE

VOLLEYBALL

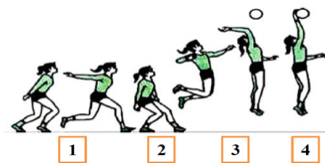
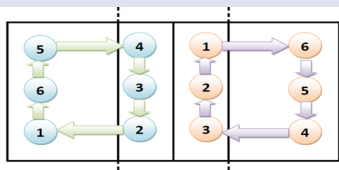

Introduction

Volleyball is a team sport played by two teams each having six players on a playing court separated by a net. The game is played for each team to send the ball regularly over the net to ground it on the opponents' court and to prevent the ball from being grounded on its own court. The ball is put into play by the right back-row player who serves the ball over the net to the opponents' court. A team is entitled to hit the ball three times in returning it to the opponents' court. A player is not allowed to hit the ball twice consecutively (except when blocking). The rally continues until the ball touches the ground or goes 'out', or a team fails to return it properly. Each team tries to score points by grounding a ball on the other team's court under organized rules.

In your previous grade levels you learned the fundamental skills of volleyball. In this unit you will learn about volleyball sport of a brief historical development of volleyball, some rules of volleyball and spiking skills of volleyball.

Unit objectives

At the end of this unit, you will be able to:

- ☞ examine the history of volleyball;
- ☞ differentiate the basic rules of volleyball game;
- ☞ demonstrate the skills of playing volleyball and,
- ☞ develop positive social and interpersonal relationship.

UNIT CONTENTS

- 5.1 A brief history of volleyball
- 5.2 Rules of volleyball
- 5.3 Spike skill of volleyball

Unit summary

Review questions

5.1 A brief history of volleyball

Specific objectives

At the end of this lesson, you will be :

- ☞ explain the development of volleyball in the world;
- ☞ describe the development of volleyball in Africa and,
- ☞ identify the development of volleyball in Ethiopia.

Start-up activities 5.1.1

1. Do you have any information about historical development of volleyball in the World, Africa and Ethiopia?
2. Is Volleyball popular in your area? Why?

5.1.1 Historical development of volleyball in the World

The volleyball sport was first introduced in 1895 in Holyoke, Massachusetts, United States of America (USA).

The primary purpose of the introduction of volleyball was a game designed as a recreation activity for business men. It was first introduced in 1895. The volleyball was introduced by William G. Morgan, a Young Men's Christian Association (here after called YMCA) who is a physical education director. The game was blended introduced by William G. Morgan, a Young Men's Christian Association (here after called YMCA) who is a physical education director. The game was blended elements of tennis, handball and basketball to create, which William G. Morgan first named "Mintonette."

In 1896 the new introduced game Mintonette was presented as exhibition at the YMCA in a nearby Springfield, Massachusetts, a businessman named Dr. Halstead suggested the name be changed to "Volleyball" because the basic idea of the game was to volley the ball back and forth over the net.

Then and onwards, volleyball sport quickly gained popularity around the world. Canada was the first "foreign" country to adopt volleyball in 1900. Six years later, Cuba discovered that the numbers of players participate in one team during volleyball game be six (6) players enter inside the volleyball court.

The Federation Internationale de Volleyball (here after called FIVB) was founded by 14 National Federations. The founders namely USA, France, Czechoslovakia, Poland, Egypt, Italy, Netherlands, Belgium, Portugal, Romania, Turkey, Brazil, Uruguay and Yugoslavia representing five different continents attended the meetings.

On the meeting held from 18 to 20 of April, the entity was officially formed, having Frenchman Paul Libaud as first president. He led the federation from 1947-1984. The volleyball game was recognized by IOC, after the game was added to the Olympic program starting in 1964. By this time, the number of national federations affiliated to the FIVB had grown to 89.

During the establishment of the FIVB the headquarter was Paris, France, while the retirement of Libaud's and the election of Mexican Ruben Acosta the FIVB headquarters transferred to Lausanne, Switzerland.



Figure 5.1 William G. Morgan

5.1.2. Historical development of volleyball in African

Volleyball entered to Africa by Egypt in 1915 and it became the first country to learn and put in to practice the rules of playing the game. It was also the first African country to be one of the founders FIVB in 1947. Two decades later, the African volleyball Commission was founded in 1967.

The African Volleyball Confederation (CAVB) was established in 1972, when the FIVB turned its five volleyball zone commissions into continental confederations. African Volleyball Confederation (French: Confédération Africaine de Volleyball, or CAVB)

is the continental governing body for the sport of volleyball in Africa. Its head quarters is located in Cairo, Egypt. The CAVB is responsible for national volley ball federations located in Africa and organizes continental competitions such as the African volleyball championship.

5.1.3. Historical development of volleyball in Ethiopia

Volleyball was introduced in Ethiopia around 1943 by foreign teachers. The game was played as recreation in schools, universities and military camps. Nearly after a decade, the Ethiopian Volleyball Federation (EVF) was established in 1954. It was after another decade that Ethiopia became a member of FIVB in 1964 during Tokyo Olympic Games. Currently the volleyball sport is popular in Ethiopia and participation has been increased and spread throughout the schools, colleges, universities, military camps and clubs in the country.



Figure 5.2 Volleyball sport in Ethiopia

5.2. Rules of volleyball

Specific objectives

At the end of this lesson, you will be able to:

- ☞ list down the basic rules of volleyball;
- ☞ describe the importance of volleyball rules in a game and,
- ☞ apply the basic rules of volleyball while playing small sided games.

5.2.1. Facilities and equipments

Start-up activity 5.2.1

1. Do you know the difference between facilities and equipment in the rule of volleyball sport?
2. Do you have a chance to watch volleyball competitions in your area? If your response is yes, share what you observe during competition.

5.2.1.1 Playing area

The playing area of volleyball includes the playing court and the free zone. This playing court has to be rectangular and symmetrical.

The playing court dimensions is a rectangle measuring 18 x 9 m, surrounded by a free zone which is a minimum of 3 m wide on all sides. The surface must be flat, horizontal and uniform. It must not present any danger of injury to the players. It is forbidden to play on rough or slippery surfaces. All lines are 5 cm wide. They must be of a light colour which is different from the colour of the floor and from any other lines.

Zones and areas

Front zone on each court, is limited by the axis of the center line and the rear edge of the attack line. It is considered to extend beyond the side lines to the end of the free zone.

The service zone is a 9 m wide area behind each end line. The substitution zone is limited by the extension of both attack lines up to the scorer's table. The libero replacement zone is part of the free zone on the side of the team benches, limited by the extension of the attack line up to the end line.

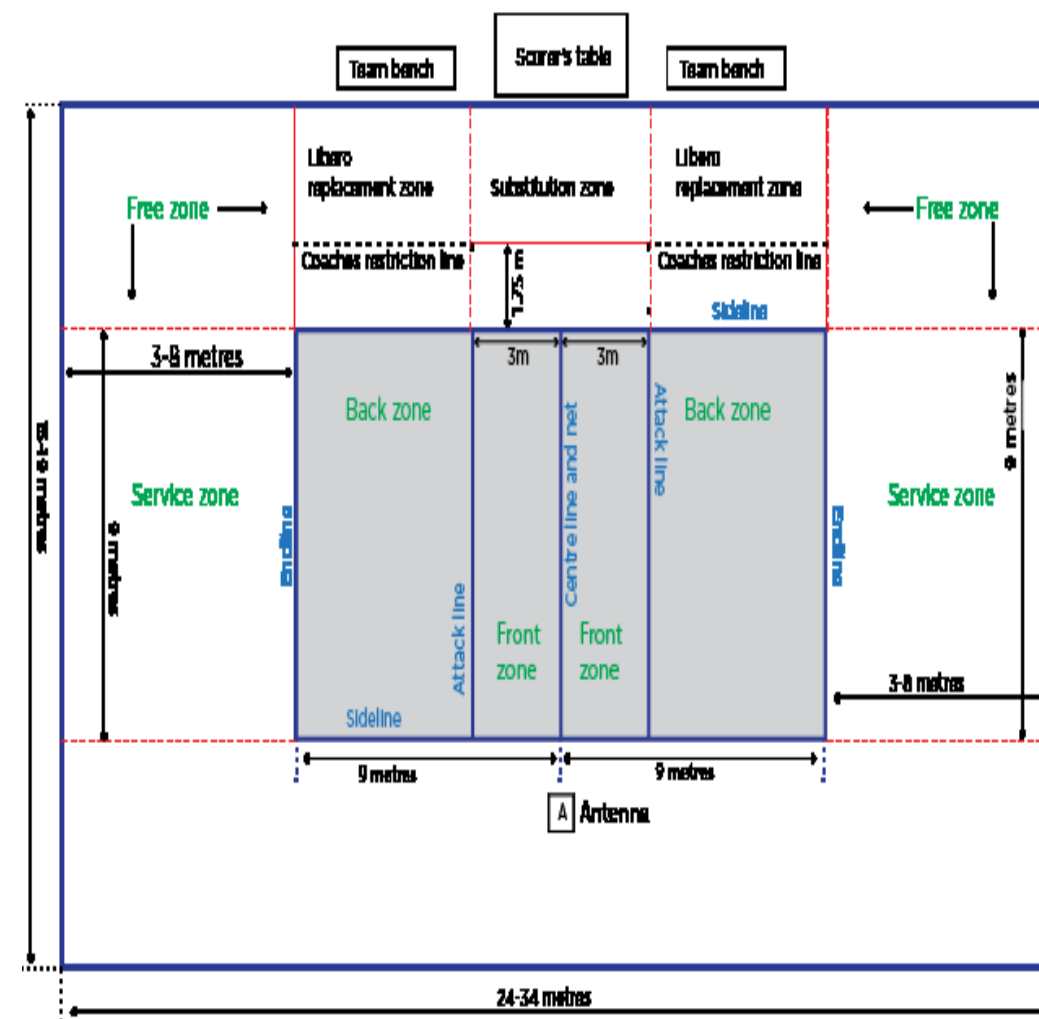

Figure 5.3 Volleyball playing area

For official competitions, the warm-up areas, sized approximately 3 x 3 m, are located in both of the bench side corners, outside the free zone. A penalty area, sized approximately 1 x 1 m and equipped with two chairs, is located in the control area, outside the prolongation of each end line. They may be limited by a 5 cm wide red line.

5.2.1.2 Net and posts

The net is 1 meter wide and 9.50 to 10 meter (m) long (with 25 to 50 centimeters (cm) on each side of the side bands, made of 10 cm square black mesh. The posts supporting the net are placed at a distance of 0.50 -1.00 meter outside the side lines. They are 2.55 meter high and preferably adjustable. The posts placed vertically over the center line. There is a net whose top is set at the height of 2.43 m for men and 2.24 m for women. Two white bands are fastened vertically to the net and placed directly above each side line. An antenna is a flexible rod, 1.80 m long and 10 mm in diameter, made of fiberglass or similar material.

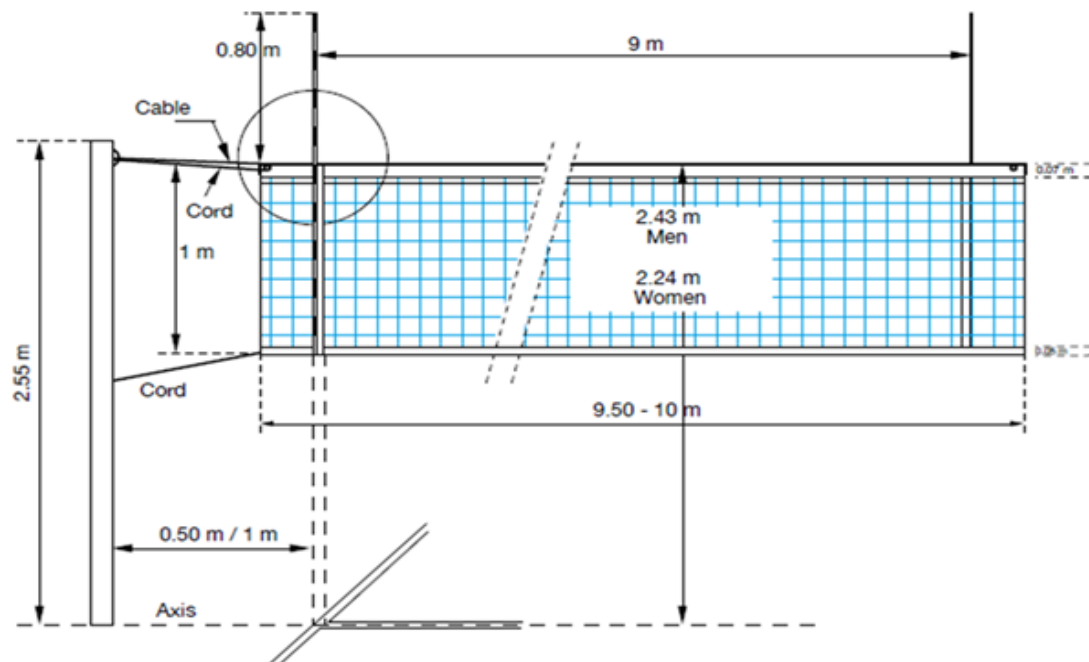

Figure 5.4 Posts, net, bands and antennas of volleyball ball game

5.2.1.3 Balls

The ball shall be spherical, made of a flexible leather or synthetic leather case with a bladder inside, made of rubber or a similar material. Its colour may be a uniform light colour or a combination of colours. Synthetic leather material and colour combinations of balls used in international official competitions should comply with FIVB standards. Its circumference is 65-67 cm and its weight is 260-280 g. Its inside pressure shall be 0.30 to 0.325 kg/cm².

5.2.2. Participants

Teams

For the match, a team may consist of up to 12 players (during competition two opponent teams must register six (6) players who enter to play), coaching staff consists of one coach and a maximum of two assistant coaches and medical staff consists of one team therapist and one medical doctor.

Only those listed on the score sheet may normally enter the competition/control area and take part in the official warm up and in the match.

The players not in play should either sit on their team bench or be in their warm-up area. The coach and other team members sit on the bench, but may temporarily leave it. The benches for the teams are located beside the scorer's table, outside the free zone. A player's equipment consists of a jersey, shorts, socks (the uniform) and sport shoes. The colour and the design for the jerseys, shorts and socks must be uniform for the team (except for the Libero).

The uniforms must be clean. The shoes must be light and flexible with rubber or composite soles without heels. Players' jerseys must be numbered from 1 to 20.

5.2.3. Playing format

5.2.3.1. Score points

A team scores a point by successfully landing the ball on the opponent's court; when the opponent team commits a fault and when the opponent team receives a penalty. If a team commits a fault by making a playing action contrary to the rules, the referees judge the faults and determine the consequences according to the rules. If two or more faults are committed successively, only the first one is counted.

A set (except the deciding 5th set) is won by the team which first scores 25 points with a minimum lead of two points. In the case of a 24-24 tie, a play is continued until a two-point lead is achieved. The match is won by the team that wins three sets. In the case of a 2-2 tie, the deciding 5th set is played to 15 points with a minimum lead of 2 points.

5.2.3.2. Structure of play

Before the match the 1st referee carries out a toss to decide upon the first service and the sides of the court in the first set. If a deciding set is to be played, a new toss will be carried out. The toss is taken in the presence of the two team captains. The winner of the toss chooses either the right to serve or to receive the service in the side of the

The loser takes the remaining choice. court. There must always be six players per team in a play. The team's starting line-up indicates the rotational order of the players on the court. This order must be maintained throughout the set. Before the start of each set, the coach has to present the starting line-up of his/her team on a line-up sheet or via the electronic device, if used. The sheet is submitted, duly filled in and signed, to the 2nd referee or the scorer.

The rotational order is determined by the team's starting line-up and controlled with the service order and players' positions throughout the set. When the receiving team has gained the right to serve, its players rotate one position clock-wise: the player in position 2 rotates to position 1 to serve; the player in position 1 rotates to position 6, etc. A rotational fault is committed when the service is not made according to the rotational order. It leads to the following consequences in order.

The scorer stops play by the buzzer; the opponent gains a point and next service. If the rotational fault is determined only after the completion of the rally which started with a rotational fault, only a single point is awarded to the opponent, regardless of the result of the rally played.

Team A (chooses first service) Team B (chooses sides of the court)

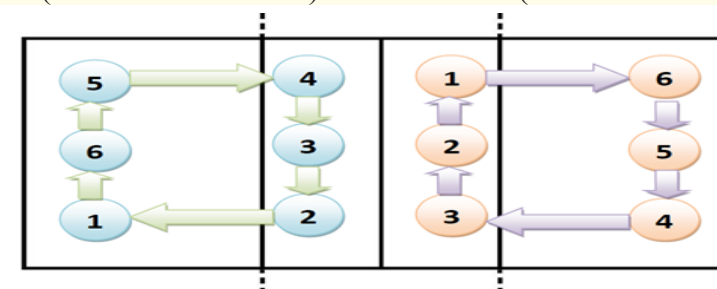

Figure 5.5 Rotational orders of two teams on court

5.2.4. Playing action

States of play

The ball is in play from the moment of the hit of the service authorized by the 1st referee. The ball is out of play at the moment of the fault which is whistled by one of the referees; in the absence of a fault, at the moment of the whistle. The ball is in if at any moment of its contact with the floor, some part of the ball touches the court, including the boundary lines.

The ball is out when all parts of the ball which contact the floor are completely outside the boundary lines. If it also touches an object outside the court, the ceiling or a person out of play, touches the antennae, ropes, posts or the net itself outside the side bands, crosses the vertical plane of the net either partially or totally outside the crossing space, crosses completely the lower space under the net. Blocking faults is when a back-row player or a Libero completes a block or participates in a completed block.

5.3. Spike skill of volleyball

Specific objectives

At the end of this lesson you will be able to:

- ☞ identify different types of volleyball spiking skills and,
- ☞ demonstrate different exercise which develop volleyball spiking skills.

Start-up activity 5.3.1

Can you mention some of the skills in volleyball playing?

Introduction

Volleyball is a popular sport played by males and females of all ages and abilities. There are five major skills in

volleyball which include service, pass, set, spike and block.

Volleyball players are skilled in all of these areas, but most of them excel in one specific skill. Players of all levels are constantly looking for ways to improve their skills and take their game to the next level. Having a successful volleyball training advantage is vital in staying with and excelling past the competition.

Spiking is the most important offensive tool for a volleyball team and the primary method of scoring points. The attack is one of the most frequent plays leading to a score in volleyball. Spiking in volleyball is divided into three main categories: tempo (the speed of the set), power (how hard the ball is hit), and targeting (how the ball is directed). When a team has volleyball hitters that can jump higher, maintain great timing in meeting the volleyball, hit the volleyball at the right spot and make it difficult for the other team to return it, that team has higher chances of being successful. A volleyball hitter must remember that the volleyball needs to stay in front of the hitting shoulder. In order to do this the hitter must watch the volleyball from the time it leaves the setters hands.

Here you are learning about volleyball skill of spiking the application of each steps consideration during game situation.

5.3.1 Improving volleyball spiking skills

Vertical jumps, speed, agility, and overall explosive power are needed to block, dive, set, serve, and spike. Adding overall strength to the development of these specific skills through the use of the resistance

exercise enables volleyball players to warm up, stretch, and practice as they work to reach their full potential. Although volleyball is considered a non-contact sport, injury often occurs because of the act of continuous jumping, diving, and high volume of movements. Therefore, volleyball players must train properly to protect the lower back, shoulders, legs, and knees. Warming up and stretching help players protect their joints and reduce the risk of injury as they build explosive power, move more freely, and achieve a greater range of motion.

5.3.2 Volleyball techniques for spiking

Specific objectives

At the end of this lesson, you will be able to:

- ☞ identify types of spike in volleyball;
- ☞ perform types of spike in volleyball and,
- ☞ demonstrate steps of spike in volleyball.

The attack is one of the most frequent plays leading to a score in volleyball. Spiking the volleyball is what generates points, and points are what generate wins. When a team has volleyball hitters that can jump higher, maintain great timing in meeting the volleyball, hit the volleyball at the right spot and make it difficult for the other team to return it, that team has higher chances of being successful. A volleyball hitter must remember that the volleyball needs to stay in front of the hitting shoulder. In order to do this the hitter must watch the volleyball from the time it leaves the setters hands.

Activity 5.4.1

Students, be in pair and practice consistent footwork for spiking. To do this, begin

approach. Mind you that volleyball spiking technique consists of three or four footsteps. The three step approach will be: left-right-left for right handed spikers/attackers, right-left-right for left handed spikers/attackers.

Volleyball techniques for executing an attack hit include four stages:

The attacking techniques of volleyball are the approach to the net, the take-off, the movements of the body in the air prior to hitting the ball and the hitting action.

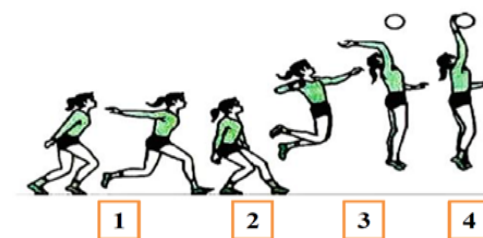

Figure 5.6 Volleyball Spiking Stages

5.3.3 Spike in volleyball

Ready position for spiking

The attacker (spikers) should stand in a relaxed position with arms comfortable at the sides. Stand about 2 to 4 meter off the net, ready to be set.

The approach

The volleyball approach is one of the most fun athletic movements in volleyball. The four-step movement is the most common approach used in volleyball. For right-handed volleyball players the movements of approach are right-left-right-left foot steps performed. On the other hand, for left-handed volleyball players the movements should be left-right-left-right alternative steps. Steps two to three are a need to be quick and explosive.

The goal of the approach is to build momentum, a player must accelerate as he or she progresses through the approach. Building momentum at this point increases speed, which, in turn, converts to a much higher vertical jump. We might then think of the steps of the approach as “slow, faster, and fastest” or perhaps even “small, bigger, and biggest.” The last two steps are the fastest and result in a two-footed approach jump.

As you start your approach, swing your arms back in a relaxed manner. Then bring them forward as you're taking your last steps. Your arms should come forward in rhythms with your jump.

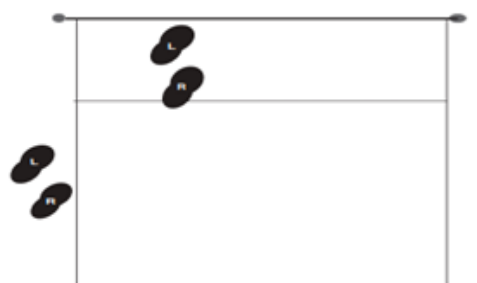

Figure 5.7 Right-handed approach pattern

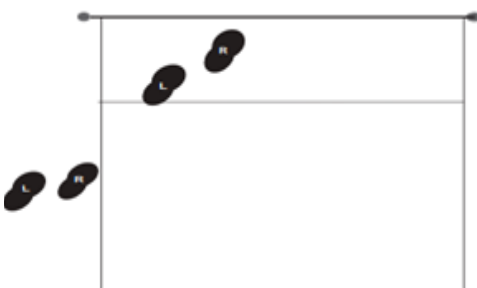

Figure 5.8 Left-handed approach pattern

Contacting the ball

When contacting the ball, your hand should be firm and hard. Get your hand on top of the ball, striking the ball in the center.

You have to focus on making the ball have topspin.

Tips for Spiking volleyball

Reach high, contact the ball high forcing the ball to have topspin. First focus on the ball contact. Have students stand on a platform at the net and focus on good contacts. Next, focus on footwork. Work on mastering the approach. Get students comfortable with taking the steps. The last thing to work on is spiking off a set. This is where you bring all the pieces together. If your contact is good, your approach is consistent, when you reach high and when you contact you have got to hit off a real set. This can take a while to get good at because of learning the skill of timing and adjusting to the set.

Approaching quick: to jump high, you have got to move fast. You need to focus on stepping quickly (especially the last couple) in order to maximize your jump height.

Swing your arms back: by swinging your arms back you will take advantage of elastic energy and your nervous systems stretch reflex which can add inches to your vertical.

Bring both your arms up: by bringing both your arms up you will continue with the momentum of going up which will help maximizing your height. Also, you will be in a better body position to hit.

Contact the ball in front of your hitting shoulder: it is best to contact the ball at the same spot every time you hit. This develops a consistent arm swing.

Put top-spin on the ball: being able to put top-spin on the ball when you hit allows you to have better angles when

hitting, thus more court to hit into. This is often called “snapping the wrist” when contacting the ball.

Activity 5.4.2

1. Students, individually hit size-4 volleyball ball down to the ground repeatedly.
2. Practice spiking individually and in pair on stationary position and by taking two steps take-off.
3. Students, in your group adjust the net to the height of 2 m stand one meter away from the net practice spiking at a sharp angle to the floor skills of volleyball such as hard-driven spike, off-speed spike and standing spike.

An attack hit is any playing action that involves hitting a ball over the net with the aim of scoring a point by making the ball touch the opponent's court or out of the court off an opponent blocker. When the ball goes over the net at a downward angle, it is classified as a spike. The way a player touches the ball significantly impacts the type of spike that is performed, as follows:

5.3.3.1 Standing spike

A standing spike can be performed by any player, with at least one foot in contact with the court/floor and aims to keep the ball in play by sending it over the net. These spikes are usually the easiest to receive.

- a. The student should stand facing the direction of the ball is intended to travel (most often at an angle from the set), with the feet slightly staggered shoulder width apart.
- b. The foot opposite the dominant hand should be slightly forward (left foot forward for a right-handed student) with the body weight primarily on the back foot.

c. The student's dominant arm should be held above the shoulder with the elbow pointing backward and held at the same height as the ear, and the hand pointing forward (thumb in the ear). The off arm should point in the direction the ball is intended to travel.

d. Once the student is ready to swing, the off arm will begin to drop as the dominant arm reaches high toward the ball.

e. The student's weight will shift from the back foot to the front foot, and the arm will swing into and through the ball, snapping the wrist to give the ball topspin.

5.3.3.2 Off-speed spike

An off-hit spike is a ball hit with less force than a hard-driven spike and has more control over its accuracy. These spikes are often used when the ball has a clear path to an open area of the opponent's court to minimise the chance of missing. It is also called a “safe” hit.

5.3.3.3 Hard driven spike

A hard-driven spike is when a ball hits with extreme force and usually hits with little control over its accuracy. These spikes are hit with the intention of hitting straight through a block or slamming in the ball into the court and ending the rally.

5.4.3 Mini game using spike

Introduction

Mini-volleyball is viewed as a sport activity with an educational purpose that is, fostering collaboration and teamwork, and teaching the importance of developing a strong body and a healthy mind. These characteristics of mini-volleyball can be used

joy of sports through training and playing.

Specific objectives

At the end of this lesson, you will be able to:

- ☞ apply critical thinking and problem-solving skills to create competitive and cooperative modified volleyball games that involve everyone and,
- ☞ identify respectful communication skills appropriate to cooperative participation in a mini-volleyball games.

Four person teams

The standard court of volleyball divided into two equal halves for each team. The players of one team share the court in four places two (1 and 2) players at front court and two (4 and 5) at the back court places one player near the net center, one right side of the front court, and the other two players back court are serve receiver. The setter can set from the middle of the court, delivering front and back sets for spike.

Activity 5.4.3

1. Prepare 4.5m x 9 m volleyball playing area.
2. Let students form a team that have four (4) members on each side (positions 1, 2, 4 and 5).
3. Let the teacher throws to back court player to commence rally.
4. Four (4) touches are allowed to pass to opponent team.
5. First touch must receiving the serve from the server team the back court player or the front court player.
6. Second touch (prepared for set) must be the back court player.
7. Third touch (set for spiker) must be front court hitter.
8. Fourth touch (spike) must be front court hitter.
9. Ball is defended by other court and play is continued as above
10. Once play finishes with ball one (1) coach initiate next ball,
11. First team to 10 points win.

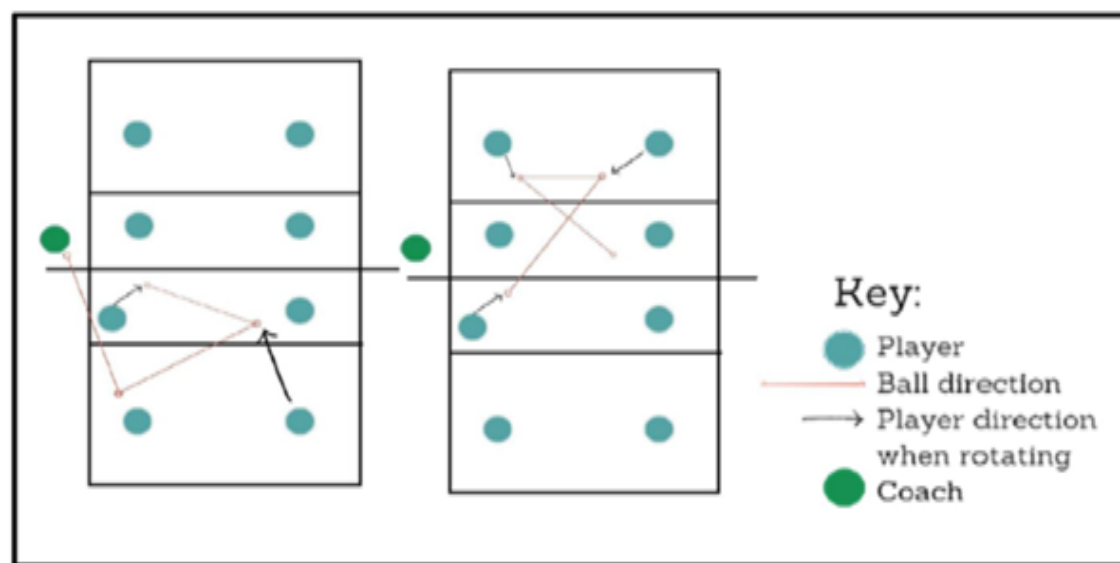

Figure 5.9 Modified Volleyball Game

5.4.4 Modified game related to volleyball

Introduction

Here, student's, you are expected familiarized with modified game related to volley ball. As the term indicates modified means the tasks and the rules of volleyball are look like volleyball. The modified games of volleyball activities are important for beginners because the activities presented in an easiest as well as joyful manner.

The main skills areas you want to focus your games around spike. Games that resemble volleyball drills can make learning the sport more fun for beginners. Considering using unconventional "balls" to help comfort student's into using original balls.

Specific objectives

At the end of this lesson, you will be able to:

- ☞ demonstrate the way how to spike the volleyball and,
- ☞ apply spiking skills whenever necessary in the volleyball game situation.

Activity 5.4.6

Students, your teacher of Health and Physical Education works with you to keep everyone focused and working as a team in this unusual game of tag. Rather than trying to get everyone else out, the goal is to keep all your teammates in. Students will practice staying focused in the midst of activity, passing the ball, and spiking the ball.

1. Let students should run around the volleyball court like they would in a game of tag while the teacher holds the volleyball.
2. The teacher will call out "Spike" or "Pass." All students should stop when they hear

one of these words.

- Let on a "Spike" call: The teacher sets a spike for one student who must spike the ball to the ground.
 - Let on a "Pass" call: The teacher also calls out a number. He passes the ball to one student and the student must pass the ball enough times to equal the called number before rolling the ball back to the teacher.
3. If a player does the wrong move, he/she sits out for the rest of the game.
 4. On a "Pass" call, the player who rolls the ball to the teacher before the allotted number of passes sits out.
 5. The ball is rolled back to the teacher, and the game continues until everyone has had at least one chance to touch the ball.
 6. If all players are still in, the group wins.

Key words:

Block, CAVB, EVF, FIVB, play format, set, spike, states of play, structure of play, rotational order and team

Unit summary

- ☞ Volleyball is a team sport played by two teams of six players on each playing court separated by a net. Volleyball was first invented in 1895 in Holyoke, Massachusetts, United States of America (USA). William G. Morgan, a YMCA physical education director blended elements of tennis, handball and basketball to create the game, which he first named "Mintonette."
- ☞ In 1896 after seeing a demonstration given at the YMCA in nearby Springfield, Massachusetts, a businessman named Dr. Halstead suggested the name be changed to "Volleyball".

☞ The Federation Internationale de Volley ball (FIVB) is founded by 14 National Federations which includes USA, France, Czechoslovakia, Poland, Egypt, Italy, Netherlands, Belgium, Portugal, Romania, Turkey, Brazil, Uruguay and Yugoslavia representing five different continents.

☞ Volleyball was included as part Olympic sport program and recognized by International Olympic Committee (IOC) in 1964. Egypt brought volleyball to Africa in 1915 and is first African country to learn the rules of volleyball. The African Volleyball Commission was founded in 1967. The African Volleyball Confederation (CAVB) was established in 1972, when the FIVB turned its five Volleyball Zone Commissions into continental confederations. Volleyball was introduced to Ethiopia around 1943 by foreign teachers. Ethiopia became a member of International Volleyball Federation (FIVB) in 1964 during Tokyo Olympic Games.

☞ The playing area of Volleyball includes the playing court and the free zone. It shall be rectangular and symmetrical. The playing court of volleyball is a rectangle measuring 18 x 9 m, surrounded by a free zone which is a minimum of 3 m wide on all sides.

☞ The net of volleyball is 1 meter wide and 9.50 to 10 meter (m) long (with 25 to 50 centimeters (cm) on each side of the side bands), made of 10 cm square black mesh. The posts supporting the volleyball net are placed at a distance of 0.50 -1.00 meter outside the side lines. They are 2.55 meter high and preferably adjustable. The posts

placed vertically over the center line. There is a net do we call top which is set at the height of 2.43 m for men and 2.24 m for women.

☞ The ball shall be spherical, made of a flexible leather or synthetic leather case with a bladder inside, made of rubber or a similar material. Its circumference is 65-67 cm and its weight is 260-280 g. Its inside pressure shall be 0.30 to 0.325 kg/cm².

☞ A spike is usually performed on the third contact after the setter; the playmaker of your team has set up the ball. The purpose of spike is to score a point for your team and finish the ongoing rally.

Unit review questions

I. Multiple Items

1. What was the original name of volleyball?
 - A. Lacrosse
 - B. Volleyball
 - C. Mintonette
 - D. Handball
2. How is the serving team chosen?
 - A. A coin tosses
 - B. Referee's choice
 - C. First team to catch the volleyball
 - D. All are answers
3. What do we call points in volleyball?
 - A. Goals
 - B. Points
 - C. Scores
 - D. Marks
4. When the ball hits the floor on one side of the net, it counts as a point for the other team.
5. What type of scoring is this called?
 - A. Point
 - B. Rally
 - C. Field

D. Progressive

5. In which way do the teams rotate in volleyball competition?

- A. Clockwise
- B. Counter-Clockwise
- C. Left-hand side
- D. Right-hand side

II. Matching Items

Column A	Column B
1. Part of the free zone on the side of the team benches, limited by the extension of the attack line up to the end line.	A. Substitution zone
2. Limited by the axis of the center line and the rear edge of the attack line.	B. Service zone
3. Limited by the extension of both attack lines up to the scorer's table.	C. Penalty zone
4. A nine meter wide area behind each end line.	D. Front zone
	E. The warm-up zone
	F. Libero replacement zone

III. Think over it

1. Spiking during volleyball game needs common understanding within team mates to overcome the opponent's team. Please describe as a team member what is expected from you to strengthen your team performance.
2. Regular physical education program participation of volleyball skill spike contributes to achieve the physical development of the students? How?
3. List three hits used most successfully while playing volleyball.

UNIT SIX

BASKETBALL



Introduction

Basketball is a popular sport played all over the world with all age categories without restrictions. Basketball has its own rules and regulations that make it popular. You can play basketball with in a very specific open space with your friends and it needs only having one post and ring (basket). This makes basketball easier as compared to other playing games. This unit will cover a brief history of basketball in the world, in Africa, and in Ethiopia. And the unit also includes some rules and skills of basketball.

Unit objectives

At the end of this unit, you will be able to:

- ☞ recognize the history of basketball;
- ☞ analyse the fundamental skills of basketball;
- ☞ demonstrate fundamental skills of basketball and,
- ☞ develop positive social and interpersonal relationship.

Unit contents

- 6.1. Brief history of basketball
- 6.2. Rules of basketball
- 6.3. Skills of basketball
 - 6.3.1. Shooting
 - 6.3.1.1. Lay-up shoot
 - 6.3.1.2. Under hand lay-up shoot
 - 6.3.1.3. Modified game

KEY WORDS:

Basketball,
History,
Skill
Shooting,
Lay-up

6.1. The brief history of basketball

6.1.1 The history of basketball in the world

Specific objectives

At the end of this lesson, you will be able to:

- ☞ explain the development of basketball and,
- ☞ tell when basketball was invented.

Start-up Activity 6.1.1

1. What do you know about basketball?
2. Are you interested to play basketball?

The records of basketball commenced in 1891 in Springfield, Massachusetts. Most of the rules and regulations of the game were once set up by means of Canadian physical education instructor James Naismith. He was the “father” of basketball.

Initially, the game basketball was once performed with a soccer ball and peach baskets, and used to be of a good deal slower tempo in contrast to the basketball games of today. The

peach baskets had been replaced by means of steel hoops and backboards via the year 1906.

By the early nineteenth century, many colleges accepted basketball as one of their sport. Soon after, high schools started to play basketball due to the little quantity of equipment and personnel wanted to play the game. In the late fifties a nicely modified orange ball was once added into the sport.



Figure 6.1 Peach Baskets

The first balls had been specifically made brown. However, in late 1950s, Tony Hinkley identified orange ball which is seen greater and which is normally used these days. Basketball used to be in the beginning performed with the soccer ball. When winter became too icy, gamers have been no longer in a position to play soccer outside. Teams have been taken indoor and it used to be appropriate to break up them half; five player on every side. The goal of the game was to shoot a ball through hoop forty six cm in diameter at a peak of 3.04 meters.

The formation of FIBA (International Basketball Association) in 1932 took basketball into an exceptional level. Basketball seems to be included in Olympics in the summer time of 1936 in Berlin, Germany for the first time.

The National Basketball league is the third largest expert league in all sports. Originally basketball was once performed by boys. However, after twelve months of its introduction, a physical education instructor at Smith College, Senda Bere nson, modified Naismith's guidelines for girls in 1921. However, it took a while for the birth of Women's National Basketball Association in the United States.

Activity 6.1.2.

Students, be in group. Then discuss and debate with each other on the role of FIBA on the development of basketball in world. Finally, reflect the group's idea to the whole class ?

Now a days, basketball is played all over the world by children, youths, men and women's without any restrictions.

6.1.2. The history of basketball in African Specific objectives

At the end of this lesson, you will be able to:

- ☞ tell the history of African basketball and,
- ☞ describe the development of African basketball.

Basketball was once brought to Africa for the duration of the center of the twentieth century with the help of missionaries and colonial administration. Today, basketball is the second most famous sport on the continent. As the wide variety of human beings practicing it got a wider acceptance on the eve of the independence of African countries, and in order to coordinate the efforts of a range of rising federations which

indispensable to unify the regulations and to launch continental competitions.

Managers of the first African National Federations expressed their wish of integrating FIBA, the world basketball governing body. At FIBA's Sixth Congress held on the 30 and 31 August, in 1960 in Rome, Italy, the Egyptian Basketball Federation used to be allowed to organise a General Assembly in order to set an institution to rule African Basketball.

Thus, under the guidance of FIBA and at the invitation of the Egyptian Basketball Federation, twelve African countries held a Constitutive General Assembly on 11-14, 1961 of June in Cairo, Egypt. This assembly created the "Association des Fédérations Africaines de Basketball" (AFABA).

Participants of this assembly included representatives of Burkina Faso, Ethiopia, Egypt, Ghana, Guinea Conakry, Mali, Morocco, Libya, North Rhodesia, Sierra Leone, Sudan and Togo.

Activity 6.1.3

Students, do you think that AFABA has any contribution on the development of Basketball in Africa? Please discuss in your group and reflect your idea to the class.

The world basketball competition (FIBA Basketball World Cup) is organized by FIBA in every four years.

The African basketball competition (The FIBA AfroBasket), which is organized by African basketball federation (AFABA) will be held in every two years.

Currently, FIBA Africa grew to a point where every single country in Africa

has a designated team, leading to more than 54 active teams in the institution.



Figure 6.2. Basketball in Africa

6.1.3. The history of basketball in Ethiopian

Specific objectives

At the end of this lesson, you will be able to:

- ☞ describe how basketball was introduced in Ethiopia and,
- ☞ mention when basketball federation was founded.

It was believed that basketball used to be first delivered in Ethiopia through the year 1946-1947. The sport used to be added and performed by physical education instructors who came to Ethiopia from Canada in Teferi Mekonnen (Entoto comprehensive) and Kokebe Tsibah Secondary Schools.

Starting from 1950, basketball grew to become famous in many areas of Addis Ababa, particularly in primary and secondary schools. In this connection, inter school basketball games have been held each year. The competitions were equipped in the former cinema hall which used to be located in Science College of Addis Ababa University. Such sorts competitions had great contribution for the recognition of the sport basketball.

Addis Ababa Basketball Federation was founded in the year 1950. After

Activity 6.1.4

What is the contribution of EBF on the development of basketball in Ethiopia? Discuss in group and reflect it to the class.

Currently, Ethiopian Basketball Federation is organizing national premier league competition between different teams to make the game basketball popular and attractive in all over the country.

Activity 6.1.5

1. Explain how basketball was introduced in Ethiopia?
2. When and where the Ethiopian Basketball Federation was founded?

6.2. Rules of Basketball
Specific objectives

At the end of this lesson, you will be able to:

- ☞ identify the basic rules of basketball and,

☞ apply the basic rules of basketball while playing small sided games.

Start-up activity 6.2.1

1. Did you have rules while you are playing basketball?
2. What are your rules to play basketball?

Basketball has a lot of rules and regulations which are important to play the game.

These rules are designed by Federation of International Basketball Association and all members of the federation have an obligation to respect and implement all the rules without any precondition.

Hereafter, we will see some of the rules of basketball like, the playing area, equipment, playing regulations, violations, fouls, and referee.

6.2.1. The playing Area

The playing court shall have a flat, hard surface free from obstructions

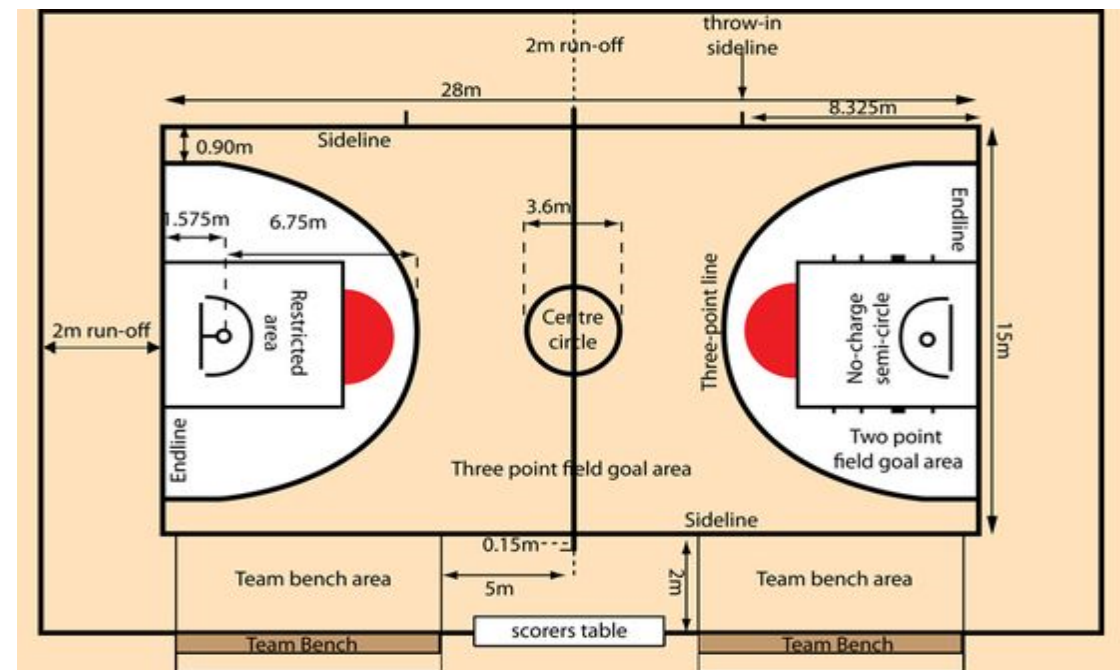

Figure 6.3. Basketball Court

A team's backcourt consists of its team's own basket, the inbounds part of the backboard and that part of the playing court limited by the end line behind its own basket, the side-lines and the centre line.

A team's frontcourt consists of the opponents' basket, the inbounds part of the backboard and that part of the playing court limited by the end-line behind the opponents' basket, the side-lines and the inner edge of the centre line nearest to the opponents' basket.

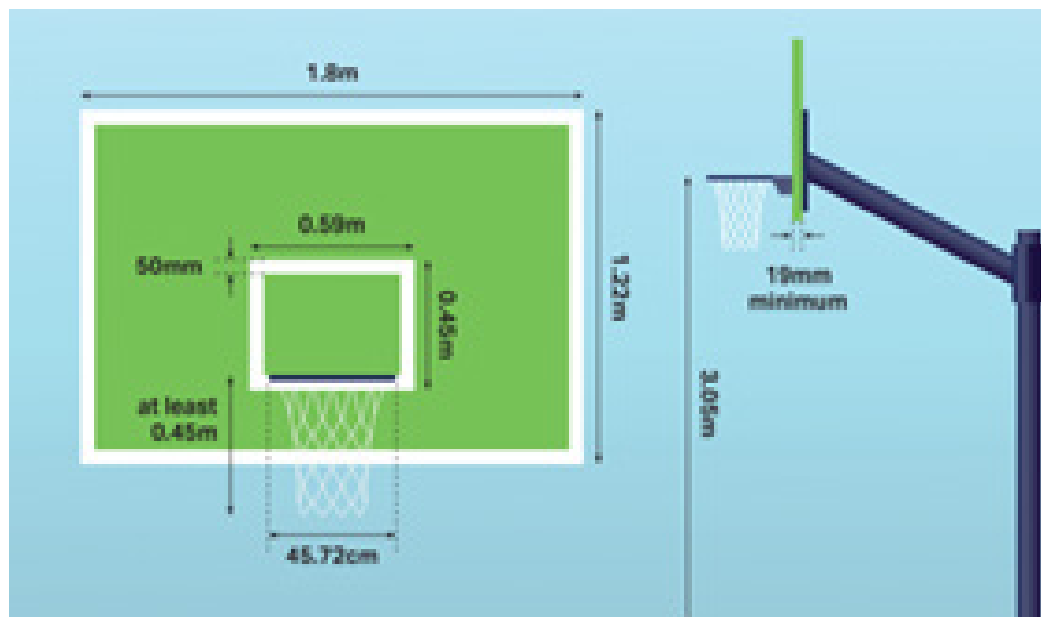

Figure 6.4. Basketball Backboard

6.2.2. Equipment

The following are descriptions of basketball equipment, which are mentioned by the international federations. These are:

a. Backstop units, consisting of:

- Backboards

- Baskets comprising

(pressure release) rings and nets

- Backboard support structures

- padding.

b. basketballs

c. game clock

d. scoreboard

e. shot clock

f. stopwatch or suitable (visible) device (not the game clock) for timing time-outs

g. two separate, distinctly different and loud signals, one of each for the

- shot clock operator,

- timer.

h. score sheet

i. player foul markers

j. team foul markers

k. alternating possession arrow

l. playing floor

m. playing court

n. adequate lighting.

6.2.3. Playing regulations

6.2.3.1. Playing time, tied score and overtime

The game shall consist of 4 quarters of 10 minutes each. There shall be an interval of play of 20 minutes before the game is scheduled to begin. There shall be the intervals of play of 2 minutes between the first and second quarter (first half), between the third and fourth quarter (second half) and before each overtimes. There shall be a half-time interval of play of 15 minutes.

If the score is tied at the end of the fourth quarter, the game shall continue as many overtimes of 5 minutes duration each as necessary to break the tie. If the aggregated score of both games for a 2-games home and away total point's series competition system is tied at the end of the second game, this game shall continue as many overtimes of 5 minutes duration each as necessary to break the tie.

Activity 6.2.2 ?

- List some rules of basketball.
- How many players are expected to start the game in basketball?
- Students, prepare a mini game in your environment and let them to play by applying the rules of the game.

6.2.4. Violations and fouls

In basketball, players are constantly moving, cutting, dribbling and handling the ball. Because of this, basketball violation does occur frequently.

The rules of basketball establish legal procedures for any player in offense or defense. Any breaking of these rules is either violation or foul. Below we shall see the two breaking of the rules.

One of the two breaking of rules is violation. Violation is an infraction of rules committed by player not against each other but concerning the equipment i.e ball and line basket. Basically, there are two categories of violation, ball handling violation and time violations

Some of the violations are:

- a player is out-of-bounds
- the ball is out-of-bounds
- double dribble
- taking more than one step with the ball without dribbling, passing and shooting
- kicking the ball with foot or lower leg
- 3 seconds
- 5 seconds in possession
- crossing the free throw line while shooting

If you commit a violation, the ball will be given to the opponent team out of bounds near where the violations occur.

Foul is an infraction of the rules concerning illegal personal contact with an opponent and/or unsportsmanlike behavior.

Any number of fouls may be called against a team. Irrespective of the penalty, each foul shall be charged, entered on the score sheet against the offender which is penalized accordingly.

Personal foul: - A personal foul is a player's illegal contact with an opponent, whether the ball is alive or dead. Some of the personal fouls are;

- holding
- pushing
- charging

- d. blocking
- f. illegal use of hands



Figure 6.5 Personal Foul

Technical fouls:

It is a kind of fouls that does not require physical contact with opponents but obey ground rule of basketball game. Including:

- a. un-sportsmen behavior
- b. disrupting referee
- c. umpire an opponent or spectators
- d. disregarding warnings given by officials
- e. delaying the game deliberately



Figure 6.6 Technical Foul

If you commit a foul, a free throw will be given to the opponent team. If you foul a player, when he is in the act of shooting to a basket, that player shall be awarded a number of free throws as follows:

- a. if the shot released from the field goal area is successful, the goal shall be count and, in addition, 1 free throw is given
- b. if the shot released from the 2-point field goal area is unsuccessful, 2 free throws.
- c. if the shot released from the 3-point field goal area is unsuccessful, 3 free throws.

A player who has committed 5 fouls shall be informed by an official and must leave the game immediately. He must be substituted within 30 seconds.



Figure 6.7 Free Throw

Activity 6.2.3

1. Students, observe a mini basketball game then, identify violation and fouls committed by players and reflect to the class.
2. Can you list some of the personal foul in basketball?
3. What is the difference between personal and technical fouls?

6.2.5. Referee

In basketball referees shall be a crew

chief and 1 or 2 umpire(s). They shall be assisted by the table officials and by a commissioner, if present.

The crew chief shall:

- a. Inspect and approve all equipment to be used during the game.
- b. Designate the official game clock, shot clock, and stopwatch and recognise the table officials.
- c. Select a game ball from at least 2 used balls provided by the home team. Should neither of these balls be suitable as the game ball, he may select the best quality ball available.
- d. Not permit any player to wear objects that may cause injury to other players.
- e. Administer a jump ball at the beginning of the first quarter and an alternating possession throw-in at the beginning of all other quarters and overtimes.
- f. Have the power to stop a game when conditions warrant it.
- g. Have the power to determine that a team shall forfeit the game.
- h. Carefully examine the score sheet at the end of playing time or at any time he feels is necessary.
- i. Approve and sign the score sheet at the end of playing time, terminating the referees' administration and connection with the game.



Figure 6.8 Referees

Therefore, players, coaches, and referees need to revise the rules of the game every year by considering that the rules might be changed from time to time.

6.3. Skills of basketball**Specific objectives**

At the end of this lesson, you will be able to:

- ☞ demonstrate the correct skill of shooting;
- ☞ apply critical thinking skills in a game;
- ☞ demonstrate respectful communication skills appropriate to cooperative participation in activities;
- ☞ show responsibility for various roles while participating in games and,
- ☞ accept ideas from other team members.

Start-up activity 6.3.1

1. Students, do you know how to score points in basketball?
2. Can you demonstrate how to throw the ball to the basket?

Students, do you remember your elementary class of physical education lessons which focused on fundamental skills of basketball? I hope you remembered some of the points you learnt about basic stance, ball handling, receiving, passing, dribbling and others.

In this section, you are going to learn about shooting in basketball. Shooting in basketball is considered as a backbone of the game. As, it is the ability to shot accurately, that determines the winner of the game.

6.3.1. Under hand lay-up shoot

Specific objectives

At the end of this lesson, you will be able to:

- ☞ describe lay-up shooting skill of basketball;
- ☞ perform lay-up shooting activates in basketball and,
- ☞ demonstrate lay-up shooting skills at least once from the three trials.

There are different types of shooting in basketball. Lay-up shoot is considered as one of the most accurate and the easiest shot in the game situation. Since you are moving toward the basket when making a layup, the most important part of a layup to master is the footwork. Learning how to do a layup from both the left and right side of the basket will increase your ability to score against your opponents.

To perform lay-up shoot, use the following steps,

1. Dribble close to the basket with your right hand;

If you are performing a right handed lay-up, make your angle towards the right side of the basket, but do not be so close to the board because you will end up under it.



Figure 6.9
Right Hand Dribbling

Layups are often taken off of a running dribble: Practice approaching the basket slowly at first, and increase your speed once you've got the footwork down.

2. Step toward the basket with your right foot.



Figure 6.10
Stepping Toward the Basket with Right Foot

When you are just a few meter from the basket, take a step toward it with your right foot. Use this step to gain distance and position yourself within easy shooting range. Dribble the ball one last time just outside your right foot.

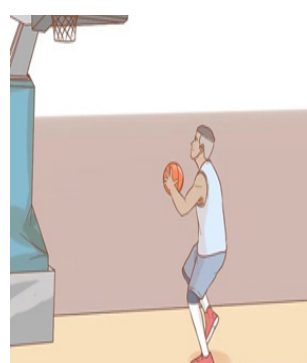

Figure 6.11
Jumping off left foot

As soon as your left foot lands, use it to jump in the direction of the basket. Your body should be moving toward the basket, but don't lean forward. Ideally, you'll be positioned close enough to the basket that you can jump straight up to take your shot.

As you jump, bring the ball out of the dribble to your chest to prepare for the shot.

A. Shoot with your right arm as you lift your right leg

As you jump, imagine a string attached to your right arm and your right leg. Move them at the same time as you shoot, as though someone were pulling upward on



Figure 6.12
Shooting with Right Arm

B. Aim for the sweet spot on the backboard

One of the reasons a layup is such a sure bet is because you can always use the backboard to help ease the shot into the basket. When you are doing a right-handed layup, the sweet spot is slightly above the top right corner of the small square in the center of the backboard. This spot absorbs the impact of the ball and drops it right down through the net.



Figure 6.13
(a) Aiming to the Spot



Figure 6.13
(b) Aiming to the Spot

C. Practice until your muscles remember the movement

The layup is a fundamental basketball move that will become second nature after you practice it enough. You should get to the point where your body remembers what to do and you don't have to think about which foot to put forward and which one to jump off: you just do it. Do layups as part of every basketball practice.



Figure 6.14
Layup Shot Practice

As you practice, you will start to get a good sense for how fast to approach the basket and from what distance to begin your layup footwork and launch into a jump.

Work on doing layups while you are being defended or off of a long pass.

Note: Do not forget to use both hands while practicing lay-up shoots.

Activity 6.3.2

Students watch basketball games in your village. Then, design at least three activities related to lay-up shoot and demonstrate it in the class.

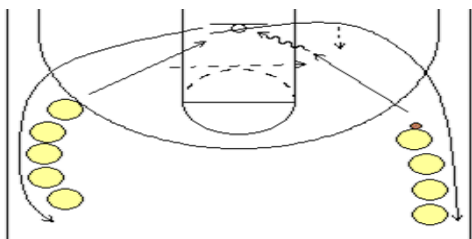

Figure 6.15. Shooting Practice Drill

6.3.2. Modified game related to basketball**Specific objectives**

At the end of this lesson, you will be able to:

- ☞ recognise responsibilities in a team;
- ☞ perform socialization skills in a basketball game
- ☞ respect others role in a game and,
- ☞ apply under-hand lay-up shoot skills.

Students, the objectives of learning all skills are to implement them in the game situations. Thus, to apply all skills in the game of basketball, it needs first to make you familiarized with skills through modified games.

Your teacher can pick and choose which modifications they deem appropriate for their session.

Play 2 v 2, ½ courts

- Lower the basketball rings.
- Play half court instead of full court.
- Use a smaller basketball e.g size 4 or 5 or you can use volleyball.
- Introduction of rules.
- Only two dribbling will be permitted
- Once the team enter to the offensive

half, they must receive and make one dribble before shooting.

- The same person cannot score more than twice in a game.
- Once the team enter to the offensive half, they must receive and make one dribble before shooting.
- The same person cannot score more than twice in a game.

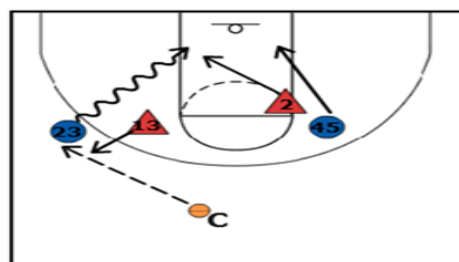

Figure 6.16 2 on 2 Half Court Game

The other modified game that you are going to play is 3vs 3 by modified number of players in one court and you can make half court. Then make a group of three students in one team and you will have a total of six students in a court.

Students, while you are making a group to play the modified game, respect each other by considering the modified rules of the game. Then, you are going to be competing with each other regarding the lay-up shoot game. During the competition, every member of the group must participate actively as a ground rule. Use both hands while you are playing this game. When you are going to shoot, it is mandatory to use both hands. Finally, the winner of this game will be the team which scores more points than the opponent teams.



Figure 6.17 Dribbling and Shooting Relay Race

Note: Students, you can also design and practice another modified game using the combination of different skills of basketball with lay-up shoot in your village.

Unit summary

- ☞ The history of basketball has been associated with Dr. James Naismith who was a physical education director at the college in Springfield, Massachusetts.
- ☞ Basketball was originally played with the soccer ball.
- ☞ The peach basket was used for goals.
- ☞ Originally, basketball was played by boys, but after a year of its introduction, a physical education teacher at Smith College, Senda Berenson, modified Naismith's rules for women in 1892.
- ☞ The International Basketball Association (FIBA) was established in 1932.
- ☞ Basketball appeared in Olympics for the first time in the summer of 1936 in Berlin, Germany.
- ☞ Basketball was introduced in Africa during the middle of the 20th century by missionaries and colonial administration.
- ☞ In June, 1961, the "Association des Fédérations Africaines de Basketball" (AFABA) was established in Cairo, Egypt.

☞ Basketball was first introduced in Ethiopia by the year 1946-1947 by physical education teachers who came from Canada in Teferi Mekonnen (Entoto comprehensive) and Kokebe Tsibah secondary schools.

☞ Addis Ababa Basketball Federation was established in the year 1950.

☞ The Ethiopian Basketball Federation became a member of Federation of International Basketball Association (FIBA) by the year 1949.

☞ Currently, Ethiopian Basketball Federation is organizing national premier league competition between different teams.

☞ Basketball has a lot of rules and regulations which are important to play this interesting game.

☞ Some of the rules of basketball are playing area, referee, violations, and fouls.

☞ In the game basketball, a player must demonstrate different skills like shooting to the basket.

☞ Lay-up shoot is one of the shooting techniques that the players have used frequently to score a basket.

Review questions

I. Choose the best answer from the given alternatives.

1. When were the International Basketball Federation established?

- A. 1932
- B. 1891
- C. 1961
- D. 1950

2. When and where was the Association des Fédérations Africaines de Basketball" (AFABA) established?

- A. 1961, Cairo, Egypt
 B. 1950, Addis Ababa, Ethiopia
 C. 1932, Dakar, Senegal
 D. 1949, Aligers, Tunisia.
3. Which one of the following is violation in basketball game?
 A. A player is out-of-bounds
 B. Holding
 C. Pushing
 D. Charging
4. Which one of the following is considered as personal foul in basketball?
 A. Holding
 B. Un sportsmen behaviour.
 C. Disrupting referee
 D. Delaying the game by deliberately
5. Which one of the following is the first step in lay-up shoot?
 A. Dribbling and approach to the basket
 B. Step towards the basket
 C. Jump towards the basket
 D. All

II. Read and answer the following questions

6. What is it called when a person dribbles with both hands at the same time? Please discuss with appropriate practical exam ple.
7. What kind of foul is physical contact between two players? Please try to name, discuss and demonstrate the foul in pro per manner.
8. How many players does a basketball team consist of and how many can play at a time? Please discuss in group and present your answer to the whole class.
- 9 Do you know the measurements of basketball court? Please sketch the dia gram with appropriate dimension and make a model of the basketball court from used material. Then bring and show the class your designed model basketball court.

UNIT SEVEN

HANDBALL







Introduction

Handball is a team sport in which two teams of seven players each pass a ball using their hands with the aim of throwing it into the goal of the other team. A standard match consists of two periods of 30 minutes, and the team that scores more goals wins. The players must follow all the fair play rules and sports regulations issued in order to keep the game attractive.

Handball is a relatively rapid learning of this game, based on natural human motion, and has allowed it to be popularized quickly. The game is not only influenced by physical fitness. Like any physical activity it is performed and generated by thinking. Moreover, handball is a team game, so it plays an important role in education. In this section you will learn about a brief history of handball in the world, in Africa and Ethiopia, some rules of handball, basic rules of handball and modified game related to handball.

Unit objectives

At the end of this unit, you will able to:

-  understand the history of handball;
-  know the skill of handball;
-  develop correct handball skills and,
-  improve positive social and interpersonal relationship.



UNIT CONTENTS

- 7.1 A brief history of handball
- 7.2 Rules of handball
- 7.3 Basic skills of handball
- 7.4 Modified game related to handball
- Unit summary
- Review questions

7.1 A brief history of handball

Specific objectives

At the end of this lesson, you will be

- able to:
-  explain the development of handball in the world;
 -  describe the development of handball in Africa and,
 -  identify the development of handball in Ethiopia.

Start-up activity 7.1.1

Do you have information before about historical development of handball in Ethiopia, in Africa and in the World?

7.1.1 A brief history of handball in the World

There are records of handball-style games going back to antiquity. The games of “Urania” played by the ancient Greeks (and described

in the Odyssey) and “Harpaston” played by the Romans (described by the Roman doctor Claudius Galenus in 130 to 200 A.D.) as well as in the “Fangballspiel” (‘catch ball game’) featured in the songs of the German lyrical poet Walther von der Vogelweide (1170-1230) all contained certain features that can be described as ancient forms of handball.

The founding fathers of field handball were probably German physical education experts who gained recognition for field handball as a separate sport at the turn of the century, based on the games of “Raffball” (‘snatch ball’) and “Königsbergerball” (Konrad Koch 1846-1911). In Sweden it was G. Wallström who introduced his country to a certain sport named “handball” in 1910.

Three games, considered as predecessor of handball sport evolved almost at the same time: Haandboldm, Hazena and Torball. The basic idea of game haandboldm is connected to Holger Nielson, Danish school master, Hazena, created by Václav Karas and Antonin Kristof which was first played in Prague. On the other hand, torball evolved in Germany. The pioneer of the game was Hermann Bachmann, who set the rules and made a detailed description of the game. The three games were played by different rules. Therefore, organizing large-scale tournaments was complicated. It became necessary to unify the rules, which was done by Karl Schelenz. The new game rules came in force to stage in Berlin, in 1917. The sport’s international governing body was

first formed in 1928 as the Federation Internationale Handball Amateur, and took its current name in Copenhagen, Denmark in 1946 as the International Handball Federation (IHF). The IHF’s first president was Avery Brundage, an American who went on to become president of the International Olympic Committee (IOC).

Handball was created and developed in Denmark, Sweden and Germany in the late 19th century. Originally played outdoors as field handball, the sport first appeared at the Berlin 1936 Olympic Games. The modern indoor version made its Olympic debut at Munich in 1972. The first women’s competition was held at the Montreal 1976 Games. Handball has featured at every Olympic Games since then. The International Handball Federation (IHF), founded in 1946, is the administrating and governing body of handball and beach handball. The IHF has 209 member federations.

Handball is now played on every habitable continent on this planet. It is estimated that about seven (7) million players are registered with a club.



Figure 7.1 IHF organized handball competitions

7.1.2. A brief history of handball in Africa

The African Handball Confederation CAHB was founded on 15 January 1973 after the 2nd All-Africa Games held in Lagos (Nigeria). It represents the national handball associations of Africa under the supervision of the International Handball Federation (IHF). The African Handball Confederation referring to a (French: Confédération Africaine de Handball), is the administrating and controlling body for African team handball.

The CAHB headquarter is located in Abidjan, Ivory Coast. The motto of the organisation is “let’s building African handball together.”

The CAHB also encourages the member of federations in their training policy by the organisation offering training courses for the benefit of the technical executives such as coaches, referees and technical delegates.



Figure 7.2 CAHB organized handball competitions

7.1.3. A brief history of handball in Ethiopia

According to Ethiopian Handball Federation, handball sport was introduced in Ethiopia in 1960 E.C. by Addis Ababa University instructors. It includes participants from the police, military forces and various sections which have been provided with the relevant courses on the handball sport. Its arrangement firstly laid the ground for frequenting the handball sport among the country’s citizens.

The Ethiopian Handball Federation (EHF) was established in 1962 E.C. One year later, ten (10) clubs were established in Addis Ababa for the first time. Then, Ethiopian championship competitions were organized and conducted, due to which Ethiopia has been accredited as one of the International Handball Federation member in 1962 E.C.

As the result of the considerable effort made by the committee members of the National Handball Federation in 1964 E.C, Ethiopia has to be a member of International Handball Federation. to be a reward for Ethiopia to take part in the conference in Nuremberg and Ethiopia had taken part in the Olympic prepared in Munich city. This could be considered as the first phase of the development of handball in Ethiopia. In 1968 E.C handball has become much popular in the society than before.

In 1970 E.C consecutive courses under handball were given for handball coaches and many Ethiopian have benefited from this course and also, many courses were given for coaches

and teachers of physical education beginning from that time and onwards. Afterwards a handball game was prepared and included in the annual sport competition that was held among the different section of the police force.



Figure 7.3 Ethiopian handball federation organized men premier league handball competitions

7.2. The rules of handball

The rules of handball are unified, regulated and controlled by the chief international organization and International Handball Federation (IHF). This task is fulfilled by the national organizations in different countries.

Specific objectives

At the end of this lesson, you will be able to:

- ☞ identify the basic rules of handball and,
- ☞ apply the basic rules of handball while playing small sided games.

Start-up activity 7.2.1

Have you ever seen a handball competition in your school or somewhere else? Please discuss in a group of four what you have seen either actually or that you watched on a media.

7.2.1. Playing court

The playing court is a 40 meters long and 20 meters wide rectangle, consisting of two goal areas and a playing area. The longer boundary lines are called side lines, and the shorter ones are called goal lines. There should be a safety zone surrounding the playing court, with a width of at least 1 meter along the side lines and 2 meters behind the goal lines.

A goal is placed in the center of each outer goal line. The goals must be firmly attached to the floor or to the walls behind them. They have an interior height of 2 meters and a width of 3 meters. The goalposts are joined by a horizontal crossbar. The goalposts and the crossbar must have an 8cm square cross section on the three sides which are visible from the court. They must be painted in bands of two contrasting colours, which also contrast clearly with the background.

The goals must have a net, that should be attached in such a way that a ball thrown into the goal normally remains in the goal. All lines on the court are fully part of the area that they enclose. The goal lines shall be 8cm wide between the goalposts, whereas all other lines shall be 5cm wide. In front of each goal there is a goal area. The goal area is defined by the goal-area line (6-metre line), which is drawn as follows:

- a 3 meters long line directly in front of the goal; this line is parallel to the goal line and 6 meters away from it;
- two quarter circles, each with a radius of 6 meters, connecting the 3 meters long line with the outer goal line.

- The free throw line (9-metre line) is a broken line, drawn 3 meters outside the goal-area line. Both the segments of the line and the space between them measure 15cm. The 7-metre line is a 1 meter long line, directly in front of the goal. It is parallel to the goal line and 7 meters away from it. The goalkeeper's restraining line (the 4-metre line) is a 15cm long line, directly in front of the goal.

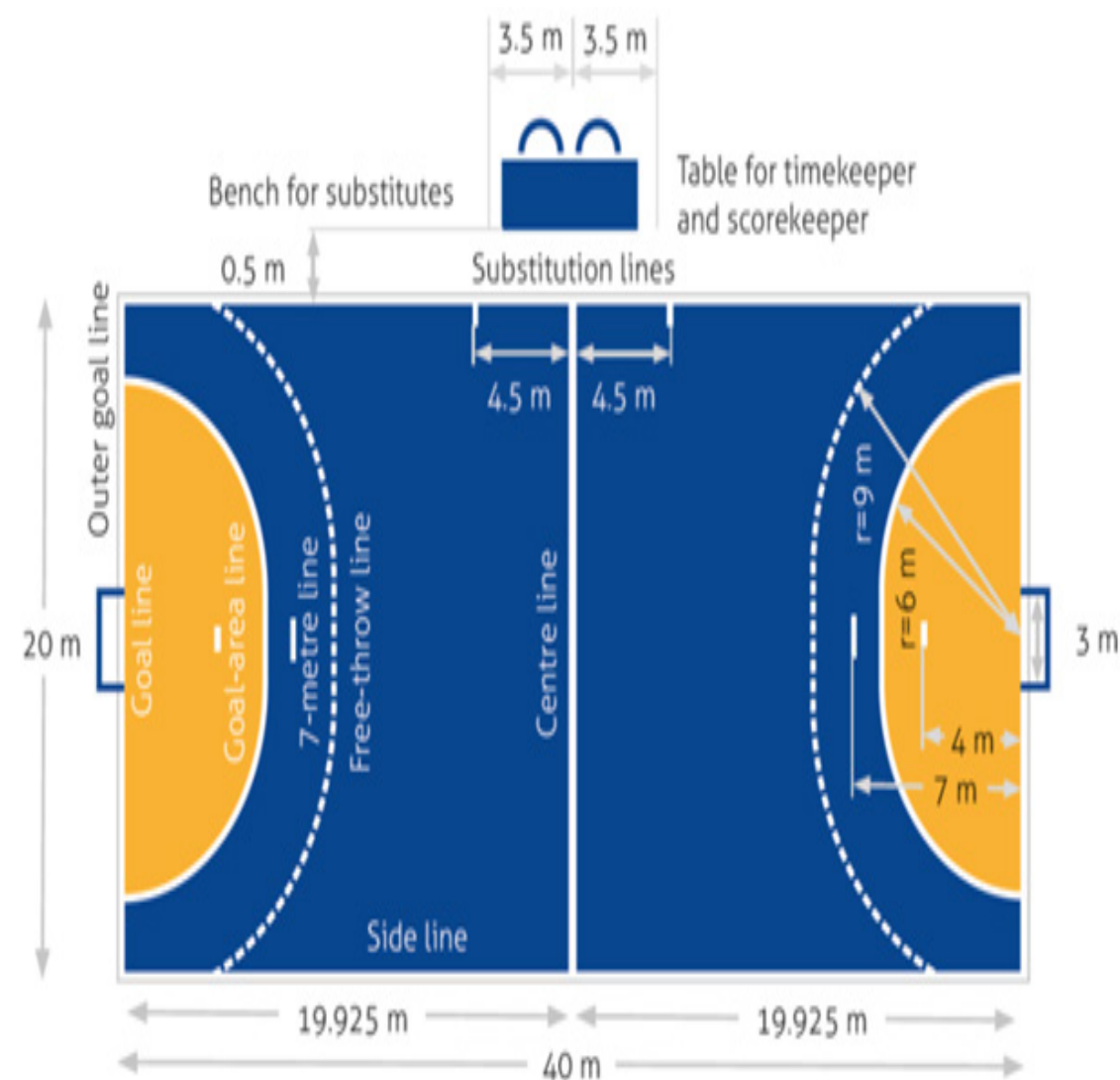

Figure 7.4 Handball Court

It is parallel to the goal line and 4 meters away from it. The center line connects the midpoints of the two side lines. The substitution line (a segment of the side line) for each team extends from the center line to a point at a distance of 4.5 meters from the center line. This end point of the substitution line is enhanced by a line which is parallel to the center line, extending 15cm inside the sideline and 15cm outside the sideline.

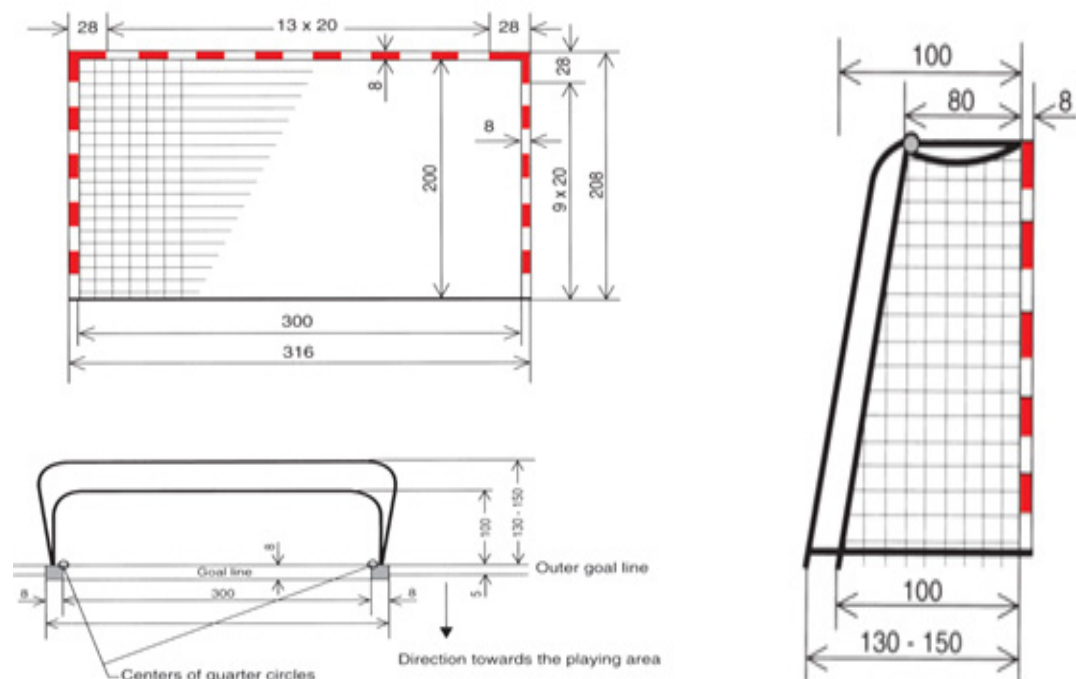

Figure 7.1 a) Handball Goal front view b) lateral view (Dimensions indicated in centimetre)

7.2.2. Playing time

The normal playing time for all teams with players of age 16 and above is 2 halves of 30 minutes. The half-time break is normally 10 minutes. The normal playing time for youth teams is 2x25 minutes in age group 12-16 and 2 x 20 minutes in age group 8-12. In both cases the half-time break is normally 10 minutes.

Overtime is played, following a 5-minute break, if a game is tied at the end of the regular playing time and a winner has to be determined. The overtime period consists of 2 halves of 5 minutes, with a 1-minute half-time break. If the game is again tied after a first overtime period, a second period is played after a 5-minute break. This overtime period also has 2 halves of 5 minutes, with a 1-minute half-time break. If the game is still tied, the winner will be determined

in accordance with the rules for the particular competition. In case that the decision is to use 7-metre throwing as tiebreaker to decide a winner, the procedures indicated below shall be followed. Each team nominates 5 players. These players make one throw each, alternating with the players of the other team.

Final signal

The playing time begins with the referee's whistle for the initial throw-off. It ends with the automatic final signal from the public clock or from the timekeeper. If such signal does not come, the referee, the timekeeper or the delegate whistles to indicate that the playing time is over.

Time-out

The referees decide on the start and the duration of an interruption ("time-out").

A time-out is obligatory when: a) a 2-minute suspension or disqualification is given; b) a team time-out is granted; c) there is a whistle signal from the timekeeper or the delegate. A time-out is normally also given in certain other situations, depending on the circumstances.

7.2.3. The ball

The ball is made of leather or a synthetic material. It must be spherical. The surface must not be shiny or slippery. The ball sizes, i.e. the circumference and weight, to be used by different categories of teams are as follows:

- 58-60cm and 425-475g (IHF Size 3) for Men and for Male Youth (over age 16);
- 54-56cm and 325-375g (IHF Size 2) for Women, Female Youth (over age 14), and Male Youth (age 12 to 16);
- 50-52cm and 290-330g (IHF Size 1) for Female Youth (age 8 to 14) and Male Youth (age 8 to 12).

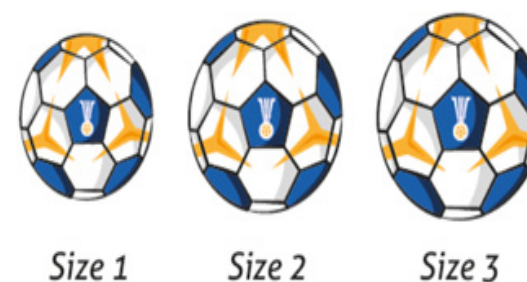

Figure 7.5 Different Sizes of Handball Ball

7.2.4. The team

A team consists of up to 14 players. No more than 7 players may be present on the court at the same time. The remaining players are substitutes. A player who is identified as a goalkeeper may become a court player at any time. Similarly, a court player may become

a goalkeeper at any time as long as he is identified as a goalkeeper. If a team is playing without a goalkeeper, a maximum number of 7 court players are allowed to be on the playing court at the same time.

A team must have at least 5 players on the court at the start of the game.

Player substitutes may enter the court, at any time and repeatedly, without notifying the timekeeper/scorekeeper, as long as the players who are replacing have already left the court. These requirements also apply to the substitution of goalkeepers. The substitution rules also apply during a time-out (except during a team time-out).

Equipment

All the court players on a team must wear identical uniforms. The combinations of colours and design for the two teams must be clearly distinguishable from each other. All players used in the goalkeeper position on a team must wear the same colour, a colour that distinguishes them from the court players of both teams and the goalkeeper(s) of the opposing team. The players must wear visible numbers that are at least 20 cm high in the back of the shirt and at least 10cm in the front. The numbers used shall be from 1 to 99. The players must wear sports shoes.

It is not permitted to wear objects that could be dangerous to the players or give players improper advantages. This includes, for instance, head protection, face masks, gloves, bracelets, watches, rings, visible piercing, necklaces or chains, earrings, glasses with out restraining bands or

with solid frames, or any other objects which could be dangerous.

Player injuries

A player who is bleeding or has blood on the body or uniform must leave the court immediately and voluntarily (through a normal substitution), in order to have the bleeding stopped, the wound covered, and the body and uniform cleaned off. The player must not return to the court until this has been done. A player who does not follow the instructions of the referees in connection with this provision is deemed guilty of bad conduct.

7.2.5. Fouls

It is not permitted to do the following fouls.

- To pull or hit the ball out of the hands of the opponent.
- To block the opponent with arms, hand, legs, or to use any part of the body to displace him or push him away; this includes a dangerous use of the elbow, both as a starting position and in motion.
- To hold an opponent (body or uniform), even if he remains free to continue the play.
- Run into or jump into an opponent.

Fouls that warrant a personal punishment

Fouls, where the action is mainly or exclusively aimed at the body of the opponent, must lead to a personal punishment. This means that, in addition to a free throw or 7-metre throw, at least the foul is to be punished progressively, beginning with a warning, then with 2-minute suspensions and disqualification.

For more severe fouls, there are 3 further levels of punishment on the basis of the

following decision-making criteria:

- fouls that are to be punished with an immediate 2-minute suspension;
- fouls that are to be punished with a disqualification;
- fouls that are to be punished with a disqualification and where a written report is required.

Fouls that warrant an immediate 2-minute suspension. For certain fouls, the punishment is a direct 2-minute suspension, regardless of whether the player had received a warning earlier.

Disqualification due to a particular reckless, particularly dangerous, premeditated or malicious action (also to be reported in writing)

If the referees find an action to be particularly reckless, particularly dangerous, premeditated or malicious, they must submit a written report after the game, so that the responsible authorities are in a position to take a decision about further measures.



Figure 7.7 Referee hand signals for (a) 2-minute suspension and (b) warning (Yellow), disqualification (red) and information written report (blue)

7.3. Basic skills of handball

In order to play handball you have to learn certain numbers of skills and you have to practice them. Handball sport too combines the skills of running, jumping, catching, and shooting, dribbling, saving, passing, blocking, step with ball, goal keeping and throwing into a fast-moving and exciting game.

Specific objectives

At the end of this lesson, you will be able to:

- perform handball goalkeeping skills and,
- apply critical thinking and problem-solving skills to create competitive and cooperation.

Start-up activity 7.3.1 ?

- Do you mention some basic role of goalkeeper during handball competition?
- Discuss with your classmate some basic movements of goalkeeper in his goal area.
- Practice the basic goalkeeping skills with your classmate.

7.3.1. Goalkeeping

Goalkeeping is probably the most important task both on offense and defense. On offense the goalkeeper initiates the fast break while on defense the goalkeeper prime function is to block shots. The two important qualities of a goalkeeper include: quickness and courage. This is so because the goalkeeper should block shots by knocking them down or to the side or over the goal line. Their main task is to prevent the other team from scoring a goal.

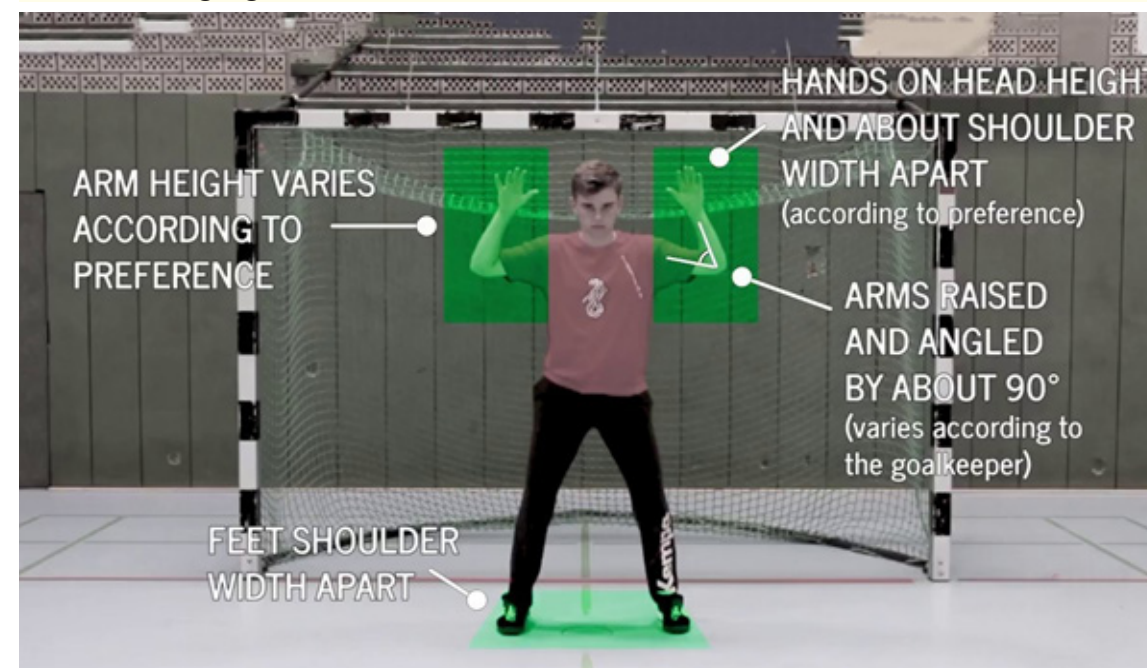

Figure 7.8 Goalkeeper basic skills

Activity 7.3.2

Work in pairs. One student tries to shoot to the goal and the other student tries to catch the ball acting as a goalkeeper. Do not let more than one pair shoot at the same time.

Start training the more specific skills for goalkeepers:

- movements in the goal.
- positioning in the goal when the opponents are shooting from different positions.
- saves with one arm, both arms, with the legs and with arms and legs.

Three in a row

There are practices that enable the goal keeper better perform in the actual playing. They include the following.

Goalkeeper is in goal area facing three ball tossers. Position the ball tossers to the left, centre, and right of the goalkeeper. Each tosser takes a turn shooting at the goal. The goalkeeper catches and returns to tosser. The goalkeeper should deflect these shots as opposed to catching them. Vary the locations of ball tosses.

Shot low practice

There are practices that enable the goal keeper better perform in the actual playing. They include the following. In group of three, one goalkeeper, one player helps the goalkeeper and one player as a tosser. The goalkeeper takes his/her position in goal with the partner standing behind. The tosser begins tossing alternating left-right low shots.

The player behind the goalkeeper grasps under their arms and assists goalkeeper into low position and helps

them get back up to a ready position.

This increases the amount of time the goalkeeper can practice the correct technique without fatigue.

Wing and a prayer

Divide players into three groups, positioned in left wing (LW), right wing (RW) and right back (RB). Goalkeeper attempts to save shots from a line of players in the LW position and RB shot from 9 meters. After the RB takes a shot, the goalkeeper quickly retrieves rebound ball and throws an outlet pass to a braking wing in the RW position.

Positional shooting

Players are placed in six (6) offensive positions with a ball. One by one each player takes a shot. Shots are taken quickly but giving the goalkeeper time to regain ready position. Change the shooting order and types and location of shots.

7.3.1.1. One-to-one: goalkeeper and a shooter**Face the goal**

One goalkeeper and one shooter are positioned inside the six (6) meter area with balls. The goalkeeper faces the end line until teacher's signal. At signal, goal keeper turns and attempts to make save on the shot. The goalkeeper spins around again facing the goal and waits for signal. The shooter should wait a second after the signal before shooting. Repeat ten (10) times retrieve balls and repeat the activity. This activity should be done quickly.

7.3.2. Goalkeeper posture and footwork

A Goalkeeper's posture should provide instant movement. The goalkeeper

slightly bent. The distance between his feet is approximately not less than 30 centimeter. That posture enables him to move rapidly one footed sideways to get a lower ball.

The body weight should be placed equally on both feet (instep) with the body slightly bent forwards, head up, eyes kept on the ball. The arms should be bent at the elbow-joints, palms at the chest or head level, elbows sideways. This arm position allows the goalkeeper to intercept the ball at various heights as, in that position, the hands have the shortest distance to the ball in any direction.

Balance and instant reactions are important. Goalkeeper start and return to ready position with feet shoulder-width apart, weight on the balls of the feet and knees slightly bent. They move side to side in small even steps following the ball, reducing angles when an attacker advances. Feet spring with hands up and out to save high shots on goal, feet slide and go wide for low saves.

Two informally named footwork styles in response to low shots:

- a. a goalkeeper assumes a proper posture from various positions (from lying position, sitting and kneeling).
- b. a goalkeeper starts from the standing position, runs a few steps, stops (on signal) and assumes proper position.
- c. two players take the position of wings close to the goal area; they pass the ball to each other. A goalkeeper changes his/her position and posture in relationship to the moving ball.
- d. from the goalkeeper's posture, moving left or right to the distance of 3 meter.
- e. three players stand in front of the goal area and they pass the ball. The goalkeeper changes his/her position and posture in relationship to the moving ball.
- f. five players stand in front of the goal area and they pass the ball (two wings and three centres). The goalkeeper changes his/her position and posture in relationship to the moving ball.

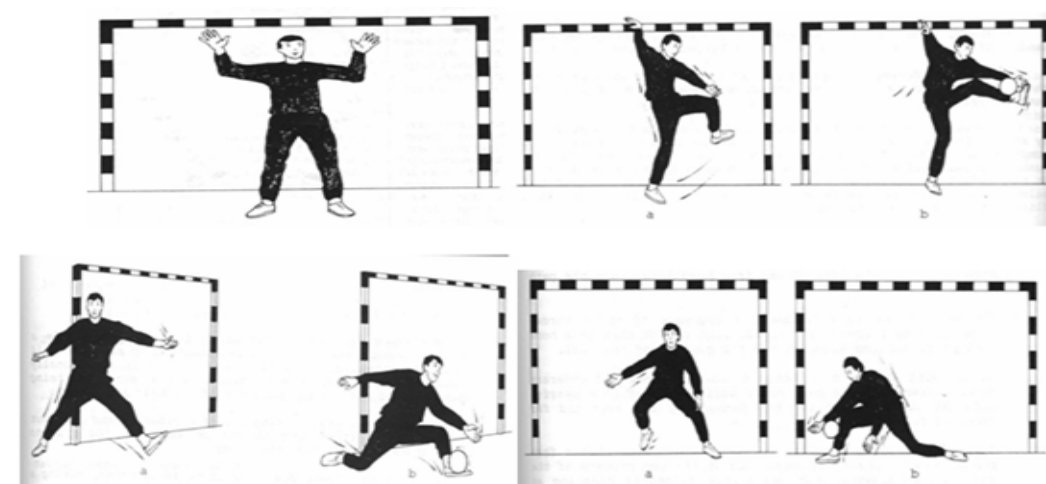

Figure 7.9 The Posture and Footwork of Goalkeeper

Activity 7.3.3

Students be in pair do shooting and goalkeeping practice turn by turn. Then being in pairs, perform passing, catching, dribbling, shooting and goalkeeping.

7.3.3. The goalkeeper's play

A goalkeeper of a handball is the only player in the team who is allowed to stay in the 6-meter zone throughout the whole competition. A goalkeeper is allowed to save the ball with all parts of his body, including two hands, trunks, and two legs and so on, only within the defending 6-meter zone.

Whenever the ball is left on the ground within the 6-meter zone, the goalkeeper owns the possession of the ball; while the ball is in the air above the 6-meter zone, the opponent can still jump in to grasp the ball without stepping in the 6-meter zone. A goalkeeper can participate in offense by long-passing the ball to a teammate in the opposing half court for a fast-break score.

Attacking technical elements of the goalkeeper

This kind of pass is the best and safest way to position the starters quickly because it can be modified easily if the defenders organize back. The over pitch is a launched attack which is aimed at the running team mate in head level. The goalkeeper can use the lob form if the opponent is in the way of the pass and the starter has opportunity to run out. For shorter destinations the other ways of passes can be used (over- under- lean or jump passes) but skilled goalkeepers can start also from sitting position or from kneeling position to make a quick launch.

Goalkeeper on the field

Naturally the goalkeeper can assist to score a goal, so he can score a goal individually, too. In some cases the goalkeeper can be changed to a field player during the game. In this situation the field player wears identical shirt with the goalkeeper.

A goalkeeper always tries to catch the ball with both hands or to put it down, because in this way he/she can start the fast attack. Effective fast attack can be initiated after precise and immediate passing of the ball forwards to a distance of 15 - 20 meter.

Students will practice technical element regarding the two forms of passing the ball for fast attack. The first form involves a goalkeeper throwing the ball strongly at first to the wings who are at a safe distance from the withdrawing defenders. In another form, a goalkeeper lobs the ball high so that it can drop down exactly. The second form is mainly performed to the player who is running in the middle of the court between the goalkeeper and the running player, there is a player who wants to intercept the ball.

7.3.4. Physical conditioning

The goalkeeper's physical conditioning should consist of flexibility exercises (bending, twisting, swinging, and lunges and so on), strength-jump exercises, speed and aerobic exercises (forward and backward movements, jumps over obstacles). Proper training and the knowledge of various exercises will develop the goalkeeper's motoric skills.

Practical activity

Students will be in pair exercising with

intervals the following activities with respect each other while give feedback how the effectiveness and the performance seems like between each intervals of exercise.

- Exercises for increasing the range of joints movements:
 - Arms circulation,
 - Legs swinging, sideways, backwards and forwards,
 - Trunk circulation, bends and trunk twisting.
- Fast stand-ups from a sitting position and prone and supine positions.
- Fast change from supine into prone position.
- One-leg skipping, swinging another leg in different directions.
- Vertical jump, then (on signal) assuming half-splits.
- Standing in the goal, right leg swings and touches the right corner and beginning with left leg assuming half-splits towards the left goal-post.
- In squatting position, moving to the right, left, then vertical jump, legs astride, fingers touch the foot, back to starting position.
- From position on the goal line, quickly standing up, touching upper left goal corner, then right.

7.4 Modified game related to handball

Handball modified match related activities in handball are fundamental and important. They are indispensable to be familiar with all the movement carried out when in position of the ball. Since the activities are a direct experience you have to be willing to acquire and to develop them.

In the following parts you will have a chance to practice passing, catching, dribbling and defensive and offensive positions by the help of modified games.

Specific objectives

At the end of this lesson, you will be able to:

- apply critical thinking and problem-solving skills to create competitive and cooperative modified handball games that involve everyone and,
- demonstrate respectful communication skills appropriate to cooperative participation in a modified handball games.

Activity 7.3.4

Students are assigned to watch their friends while they are passing; catching and dribbling the ball. At the end of the game spectators are given feedback on the skills they have been performed.

7.4.1. 2 vs 1

Be in threes, stand with your friends facing each other the third one in the middle. The one in the middle tries to intercept the ball passed by you, as shown in figure 7.10 while practices passing and catching.

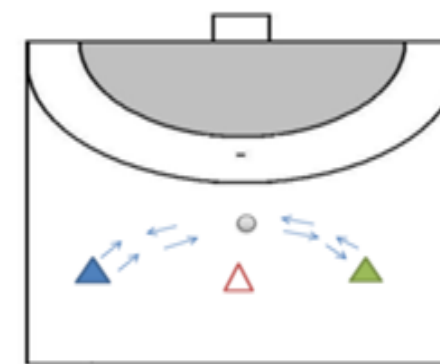

Figure 7.10 Position to practice Passing and Catching by 2 Vs 1

7.4.2. 4 vs 4

Be in two groups with the numbers of four (4) students in each side. Four students are directly concerned on participating passing, catching and dribbling combination so as to attack the other four students. The other four students occupy the seven (7) and nine (9) meters area or position to intercept or defend the students with ball (see figure 7.11).

The one waiting behind the nine meters line or the group of the passing players should be active, after the pass to the one who is approaching behind. The combination is performed by a group of four players, the defender should still wait and observe to intercept the ball.

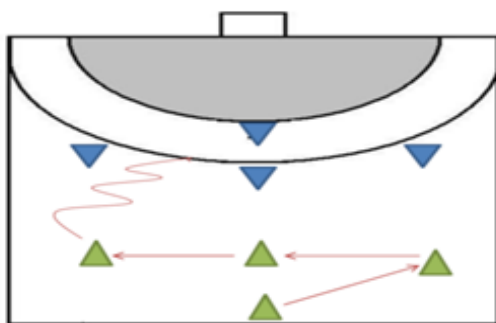

Figure 7.11 Position to practice passing, catching and dribbling on court by 4 vs 4

7.4.3. 5 Vs 5

A further basic possibility for the cooperation between players is that one player without ball runs for an open space from her/his position to another position by a longer run-up. After that she/he gets the pass from a team mate, who remains on her/his position.

In this modified game activities the offensive five plays the ball by using passing, catching and dribbling towards the defensive players' goal. The students in the defensive position follow the offensive team members to intercept the ball. After the trial of the first five attacker students the rest will take their own turn to perform the offensive activities.

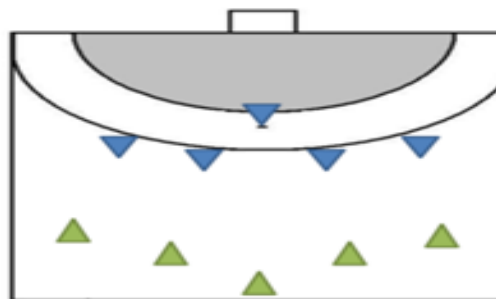

Figure 7.12 Position to practice passing, catching and dribbling on court by 5 Vs 5

7.4.7. 7 Vs 7

The playing court is subdivided into three imaginary longitudinal lanes and each of the players under the attacking side is responsible to pass the ball catch and dribble towards the opposite side. Each lane must be occupied in each phase of the attack; while leaving the lane by a player the attacker to whom she/he intends to change must occupy the lane which becomes free.

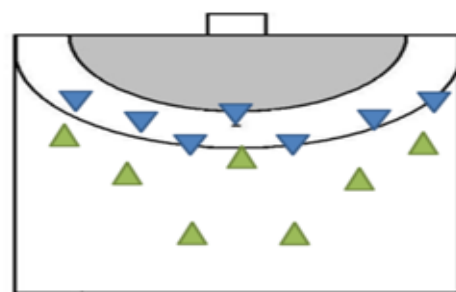

Figure 7.13 Position to practice attacking to pass, catch and dribble on court by 7 Vs 7

KEY TERMS :

African Handball Confederation (CAHB), Ethiopian handball Federation (EHB), International Handball Federation (IHF), International Olympic Committee (IOC), modified game and physical conditioning

Unit summary

- ☞ There are records of handball-style games going back to antiquity. The games of “Urania” was played by the ancient Greeks and “Harpaston” was played by the Romans as well as in the “Fangballspiel” (or ‘catch ball game’) all contained certain features that can be described as ancient forms of handball. Handball was created and developed in Denmark, Sweden and Germany in the late 19th century.
- ☞ Originally played outdoors as field handball, the sport first appeared at the Berlin 1936 Games. The modern indoor version made its Olympic debut at Munich 1972.
- ☞ The first women’s competition was held at the Montreal 1976 Games. Handball has featured at every Olympic Games since then. The International Handball Federation (IHF) founded in 1946. The IHF has 209 member federations.
- ☞ International Handball Federation (IHF) founded in 1946. The IHF has 209 member federations.
- ☞ The African Handball Confederation (CAHB) founded on 15 January 1973 after the 2nd All-Africa Games in Lagos (Nigeria). The CAHB headquarters is located in Abidjan, Ivory Coast.
- ☞ Handball was introduced to Ethiopia in 1960 E.C. by Addis Ababa University instructors. The Ethiopian Handball Federation was established in 1962 E.C. In 1964 E.C Ethiopia has become a member of International Handball Federation.
- ☞ The playing court is a 40 meters long and 20 meters wide rectangular shape. All lines on the court are fully part of the area that they enclose.
- ☞ The goal lines shall be 8cm wide between the goalposts, whereas all other lines shall be 5cm wide.
- ☞ The normal playing time for all teams with players of age 16 and above is 2 halves of 30 minutes. The half-time break is normally 10 minutes.
- ☞ A team consists of up to 14 players. No more than 7 players may be present on the court at the same time. The remaining players are substitutes.
- ☞ Handball sport combines the skills of running, jumping, catching, shooting, dribbling, saving, passing, blocking and step with ball and throwing into a fast-moving, exciting game.

Unit review questions

I. Matching Item

Column A	Column B
1. The foundation of African Handball Confederation (CAHB)	A) Urania
2. The free throw line	B) Harpaston
3. played by the ancient Greeks	C) 1973
4. The Ethiopian Handball Federation (EHF) was established	D) 1962
5. played by the Romans	E) 9 meter line

II. Multiple choice items

- The handball was first included in the Olympics as a field sport in:
 - 1900's
 - 1936
 - 1972
 - 1990
- How wide is the goal line between the posts of handball court?
 - 5 cm
 - 6 cm
 - 8 cm
 - 10 cm
- What are the required interior measurements of the goal?
 - 1.92 x 2.92meters
 - 2.00 x 3.00meters
 - 2.05 x 3.05meters
 - 2.08 x 3.08 meters
- Substitution takes place :
 - Anywhere in half of handball court.
 - Anywhere in your half court side line next to your bench.
 - Between the substitution line nearest your bench and the centre line.
 - Between the substitution line nearest your bench and the end line.
- One of the following is not allowed to hit the ball during handball competition.
 - The lower leg
 - The upper leg
 - The arm
 - The head

III. Think over it

- What makes handball unique from other invasion games?
- Handball goalkeepers needs develop physical conditioning. What makes different from court players?
- Why are rules and regulations set for handball? Describe the advantage of the rules and regulations of handball.

UNIT EIGHT

SELF-DEFENSE AND SPORT ETHICS



Introduction

Students, the first lesson to learn in Self-defense are how to protect or defend you from attackers because you are the most important one in this world. Thus, no-one has the right to hurt, intimidate or harass you. You have the right to protect yourself and you are well worth fighting for. Thus, as a person you need to defend yourself from such accidental attack from human beings by knowing and applying the ethics of self-defense. That is why self-defense is very important to you. Therefore, this unit will focus on the mechanisms that you are going to use to defend yourself from different attacks.

Unit objectives

At the end of this unit, you will be able to:

- ☞ understand fundamental techniques of self-defense;
- ☞ demonstrate interest to apply basic rules and principles of self-defense and,
- ☞ recognize the benefit of self-defense.

Unit contents

- 8.1. Essence and roles of self-defense
- 8.2. Principles and rules of self-defense
- 8.3. Basic self-defense techniques
 - 8.3.1. Basic stance
 - 8.3.2. Escape
 - 8.3.3. Strikes
 - 8.3.4. Grappling

KEY WORD

- Self-defense
- Block
- Attack
- Strike
- Escape and Grappling

8.1. Essence and roles of self-defense

Specific objectives

At the end of this lesson, you will be able to:

- ☞ explain the importance of learning self-defense activities;
- ☞ describe the roles of self-defense activities and,
- ☞ list the ethics of self-defense.

Start-up Activity 8.1.1

- What do you know about self-defense? Can you tell your ideas to the class?
- What is the importance of self-defense?

Self-defense has been practiced by numerous group people for various years. It is the act of protecting oneself when substantial assaulted, as by implies of countering blows or overcoming an aggressor: which is known as the art of self-defense. It may be a countermeasure that involves securing

the well-being of oneself or of each other from harm. Besides, the utilizing of proper self-defense as a legal defense to utilize it in times of pressure and peril is additionally accessible in numerous jurisdictions.

Students, having the ability of self-defense play an imperative position and advantage for the person who will be exposed to unsafe situations.

Activity 8.1.2 ?

Students, be in pair and discuss the benefit of learning self-defense. Reflect your idea to the whole class.

Thus, here, there are some benefits of participating in self-defense exercise program. Some of these are:

- improve your physical & mental strength
- it helps develop self-discipline;
- it teaches you self-respect;
- it works on your balance;
- it builds confidence and,
- it has a positive influence on your life.

Students, to be profited from learning of self-defense, you wish to be ethical. Self-defense has its possess moral issues. Those ethics ought to be kept by all participants. Ethics can be defened as an intemperate degree of socially mindful behavior which represents the soul of self-defense. It includes the potential of society to contain their physical make-up and intellect, not basically in their potential to central point on a method, but also to assist their day-to-day move and decisions. It is the way in which one act honestly in both word and action.

Ethics and moral concepts stem from the old-fashion and social variables

of martial arts, whereas taking into consideration cutting-edge society and its laws.

Some of its contributions are:

- the concept of peacefulness,
- respect and cordiality for others,
- loyalty to one's family, friends and country, and
- The tolerance/ resilience of those who have differing ideologies.

The followings are the key Ethical qualities. These are:

Humility

This can be a blend of not gloating approximately one's exceptionally claim capacities, whereas at the indistinguishable time not piling feedback on the capacities, or seen need of it, of others.

Respect

Regard and acknowledgment of others ought to amplify well greater than the training lobby. Respect should be demonstrated insider the family unit, toward seniors of the society, and within your put of work and schools.

Integrity / Honesty

The most essential component of genuine self-protection, for a learner is to have intemperate moral character, to be genuine in all their dealings and be in a position to act in considerate to what is conventional and right.

Courage

Courage is the capacity to procure one's dreams notwithstanding of fear. Genuine courage, from a self-defense point of view, ought to be in terms of the eagerness to shield equity and truth, in any case of peril, private

Self-control

Self-defense as Martial art expressions abilities, should not be utilized as it implies to elude ones dissatisfactions or annoyance, or to raise out ridiculous ambushes on innocent victims. Students, as a self-defense learner, you are expected to know and apply all the above stated ethics of self-defense for better performance.

Students, whenever you are going to participate in any activity or doing self-defense, you need to give special emphasis for your safety. Safety in any activity is a priority of every participant.

Activity 8.1.3 ?

Students, can you mention some safety guidelines that you have been using while doing any activities?

The followings are some of the safety guidelines that must be considered when you learn self-defense techniques in your physical education class or any other training centers.

- a. work gradually when picking up information of procedures. You wish to look at the capacity great prior than the utilize of it.
- b. wear comfortable clothing that does not cause peril to an individual or accomplice when performing self-defense techniques.
- c. before approaching your home or door you usually make positive to appear round and see if there is no-one around.
- d. do not walk alone in a dark place, let a place for this kind of people (attackers).
- e. do not wear highly-priced jewelry or baggage when you walk alone.

Students, if you follow and apply these safety guidelines, you will have a

chance to minimize potential dangers and make yourself safe from any attack.

8.2. Principles and rules of self-defense

Specific objectives

At the end of this lesson, you will be able to:

- ☞ explain the principles of Self-defense activities;
- ☞ identify the rules of self-defense activities and,
- ☞ apply principles while practicing Self-defense activities.

Like any sport competition or activities, self-defense has its own rules of activities and principles which are applied in all self-defense training or computation. The following are some principles of self-defense which are applied in training or competition.

Principle one: Alertness

Alertness is being able to competent to expect rapidly; fast to word things and cognizant of something, particularly reaction to sensible risk situation or issue. It furthermore capacity to observe scenarios in which human creature are seeking out for chance and arranged to bargain with it.

Alertness is, to a few degree, an innate personal characteristic; be that as it may it can at that point once more be realized and improved.

It has two rules. Those are:

1. Know what is behind you, and
2. Pay particular attention to anything out of place.

Be aware the following;

- a. develop “eyes within the back of your head.”
- b. use your eyes in your environment.
- c. do not enter unfamiliar areas that you cannot have a look at first.
- d. make it a workout to swing broad circular corners,
- e. use window glass for reward visibility, and get something solid behind you.

Principle Two: Decisiveness

This principle is forming choices quickly & efficaciously. The principle is exceptionally imperative for the final conclusion result of exact circumstance: the conclusive nature of an issue that has been settled. Therefore, decisiveness is having a personal defensive plan for any given situation.

Principle Three: Aggressiveness

Aggressiveness is carrying on in an bothered and savagely towards each other individual. It is habitually destructive, social exchange with the purposeful of delivering damage.

This guideline of individual defense especially applies to deadly-force circumstance, and acknowledgement of that truth as a fundamental issue of private preparedness. In protection you should not provoke violence. You have got to supply your assailant the huge gain of attacking the primary blow, or at slightest attempting to do so. But, from that point you will also return the intrigued with what must ideally be overpowering violence as the saying goes “The best defense could be a great offence.” Numerous occasions of prevalent constrain being

over-powered by outrage and hostility on the portion of the casualty spring to mind.

Principle Four: Coolness:

This is the prerequisite to controlling the environment: Control over one's passionate state is basic in utilizing sound strategies and mounting a successful defense. Having an individual strategy in mind and keeping up situational mindfulness are the crucial establishments of self-control. You must keep your head safe. On the off chance that you “lose your cool” beneath deadly attack, you'll likely not survive to form excuses.

In case you counterattack together with your hands, utilize them carefully. (Keep in mind that a blow along with your closed clenched hand to your enemy's head will nearly continuously wreck your hand. A finger in his eye is less demanding, more secure, and likely to be more decisive.)

Principle Five: Speed

Speed capacity refers to the rate at which something moves, voyages or the quality of being speedy or rapid. If you assume anybody may attack you, on the very immediate simply get it that your aggressor anticipates you serious physical hurt, you got to work fair as rapid as you'll be able. If he has shot at you, you wish to hit him prior than he can shoot once more. In the event that he is holding you by risk of drive, you've got the advantage of reaction time over him.

The stake in individual defense is your life.

You cannot bear to play by donning

No official will call it back. Therefore, in case you're assaulted, counter immediately. Be sudden. Be speedy. Speed is your salvation.

Principle Six: Surprise:

Surprise is the primary rule of attacking combat. It offers you an enormous advantage over your opponent. This need to suggest something from coming close at a point that they cannot see or indeed fair using a preventive strike before they have chance to react.

Be humble almost your ability. As the less your rival recognize of about you, the more you'll have to stun them with. However, the benefit of striking the primary blow may be an extravagance you must more often than not give to your assailant. So, in a sense there can be no key astonish in defense. But that does not cruel that the protector cannot accomplish strategic astonish. By doing so what your attacker slightest anticipates you to do, you'll throw him completely off.

Therefore, what usually least shock moment, rough, counterattack, so the principles of aggressiveness is closely tied to risk of surprise.

The following are some of basic self-defense rules that you are going to apply to keep you safe and prevent potential attackers:-

1. Know your path (way)

- a. be familiar with the courses and ways you take home or to your bug (pear) out location.
- b. knowing your course implies knowing the places individuals seem hide(close) and giving these zones a wide billet(your resting room) when passing.

- c. it implies maintaining a strategic distance from ineffectively lit or new easy routes that might get you misplaced or cornered.

2. Make sure someone knows when you are and when to expect you.

This is genuine of numerous conditions you might moreover find yourself in like climbing, traveling to or from school, or leaving within the course of a crisis contact up-to date on your place which is as basic as a fast phone call or text message.

3. Walk confidently

- a. Numerous predators are looking for any person they assume that they can over power, plenty like predator within the wild.
- b. Walk with objective and heading, paying care as you go so you keep absent from surprise.

4. Trust your instincts

If you think somebody could be coming behind you or are alarmed by somebody in near proximately it is advisable to urge to a busy area and contact somebody you believe topic you up

5. Avoid routines that could easily be followed

If conceivable escape from doing certain exercises, like pulling back numerous or taking the same schedules home or school at the same time each day.

6. Carry objects capable of making noise

- a. Cell phone, whistles, horns, etc... any thing that can alarm individuals to your situation.
- b. The sound from a crisis shriek can travel more distant and is wash than essentially shouting for help.

reply to somebody yelling fire than to somebody shouting offer assistance

- d. Self-defense organization such as safety and self-defense solutions also empower conceivable casualties of aggressors to yell “fire” to draw attention and scare off an attacker.

7. Know the sensitive area of your attacker

- a. The eyes, ears, throat, groin, knees and shins are all areas that hurt when hit point. For example an ear slaps or crotch assault can deliver you the upper hand.
- b. The bash and dash is the most effective approach. Once the assailant is harmed and his consideration is redirected, go as fast as you will to go an active area and call someone you trust.
- c. But, If your attacker gets a hold of you, you need to do everything you’ll be able to keep them from taking you to another location.

In general, students you need to follow and implement the following self-defense strategies. These are:

1. Minimize possibility of danger.
2. Know and avoid danger.
3. Use the skills only when necessary.

8.3 Basic techniques of self-defense

Specific objectives

At the end of this lesson, you will be able to:

- ☞ mention the types of self-defense skills;
- ☞ demonstrate self-defense skills;
- ☞ show respect for others;

- ☞ accept ideas from others;
- ☞ demonstrate cooperation with others and,
- ☞ correctly demonstrate three ways of escapes, strikes and grappling techniques one from each.

Activity 8.1.4. ?

1. Students, if someone tries to attack you, how will you react?
2. Do you know any mechanisms which are very important to defend yourself from attacker?

There are different self-defense techniques that peoples utilized protecting themselves from assailants. Students, here are a few of the self-defense

8.3.1. Basic stance

The goal of this stance is to position yourself in a non-threatening technique so as not to actuate a forceful person who has, through tone of voice, body sign, and vitality, shown that he or she may be getting to assault you.

Specific objectives

At the end of this lesson, students will be able to:

- ☞ describe basic stance position;
- ☞ enjoy with basic stance activates in self-defense and,
- ☞ demonstrate basic stance techniques



Figure 8. 3 Correct Stance

This position gives you with a base, turns your body a small side ways to reduce presentation of your targets, and puts your hands in a position over your attacker’s hands (weapons) so simply you can more rapidly block an approaching assault. But the position is not self-evident and is misleadingly inactive, in spite of the fact that it has arranged you for an attack.

The followings are fundamental steps of basic stance. These are:

- a. Position your feet properly
- b. Position your torso correctly
- c. Position your arms for defense
- d. Position your head defensively

8.3.2. Escape

In the previous lesson you have learnt how to perform basic stance in self-defense. Here, you are going to learn how you to escape from different individuals who need attack you accidental. In self-defense, there are different techniques that you are going to use to escape from attackers. To escape from attacker, you need to follow the steps of escape. Thus, next you will see how to escape from attackers.

Specific objectives

At the end of this lesson, you will be able to:

- ☞ describe escape techniques;
- ☞ practice basic escape techniques activates in self-defense and,
- ☞ demonstrate escape techniques at least once from the three trials.

The followings are some of the procedures which you’ll be able utilize to escape from grabs.

For cases where the aggressor is coming from behind, you can utilize this move. Focus on getting low and making space to free yourself.

To perform:

- a. Bend forward from the waist. This shifts your weight forward, making it more difficult for your attacker to pick you up. It also gives you a better angle to throw elbows from side to side to the attacker’s face.
- b. Turn into the assailant with one of your elbows and proceed counterattacking.



Figure 8.4 Escape from a ‘bear hug attack’

This should allow you space to turn completely, utilizing another move to harm the face or strike the crotch. With the space these moves have made, you’ll be able to elude and run away.

Note:

Students, in order to have good skill of self-defense techniques, you need to spend more time to practice. Thus, be in pair and practice the above technique repeatedly by changing your roles. Do not forget safety measures.

2. Escape with hands trapped

If your aggressor comes from behind and traps your arms (this is similar to a bear hug, but you won't be able to move as freely). here's what to do:

- First response ought to be to halt your attacker's arms from going higher into a headlock. Move your hips to one side. This gives an opening for strikes to the crotch with open-handed slaps.
- Bring your hand back up to your arms and raise your inverse elbow to turn into the wrap. Keep your arms tight to your chest as you're turning in.
- Stay forceful along with your knees and other counterattacks until you'll be able to disengage.



Figure 8.5 Escape with Hands Trapped

Note:

Students, in order to have good skill of self-defense techniques, you need to spend more time to practice. Thus, be in pair and practice the above technique repeatedly by changing your roles. Do not forget safety measures.

3. Escape from side headlock

When the aggressor locks their arm around your head from the side, your first instinct should be to avoid from getting choked.

To perform:

- turn into the attacker's side as much as conceivable to maintain a strategic

distance from being choked.

- with your hand that's farthest absent, strike the crotch with open-handed slaps until you've got sufficient versatility to turn your head all the way out to disengage.



Figure 8.6 Escape from side headlock

Note:

Students, in order to have good skill of self-defense techniques, you need to spend more time to practice. Thus, be in pair and practice the above technique repeatedly by changing your roles. Do not forget safety measures.

8.3.3. Strikes

Specific objectives

At the end of this lesson, you will be able to:

- ☞ describe strike techniques;
- ☞ enjoy with strikes techniques activates in self-defense and,
- ☞ demonstrate strikes techniques at least once from the three trials.

In order to strike the aggressor, first you need to block the action of the attacker. The purpose of a block is to stop a weapon that is in motion. From the ready position, your arms are already in position to block a punch or strike or even a grab.

To block the assault, you will utilize in two ways; these are the inward block and outward block. The inward block moves towards the center of your body and the fist is at eye level so that your arm covers the area of your head. Your forearm is slightly in a diagonal position but mostly vertical



Figure 8.7 Block in Self-defense

On the other hand, the outward block moves absent from the center of your body and the clenched hand is at eye level, the lower arm is for the most part vertical but is somewhat inclining advances. As you can see (Figure 8.7 and 8.8), it is directly across from the inward block; if you performed these blocks in succession (which is possible you might have to do in a real self-defense situation), it would look like a sort of windshield wiper effect traveling horizontally.



Figure 8.8 Attacking Technique

With these blocks or after performing these blocks, strikes can be added to your technique

1. Front kick to Groin

If someone is coming at you from the front, a groin kick may deliver enough force to paralyze your attacker, making your escape possible. It is particularly beneficial against somebody who is tall.

To perform:

- Start in prepared position, keeping hands up and stabilize yourself as best you can.
- Lift your prevailing leg off the ground and start to drive your knee upward.
- Extend your overwhelming leg, drive hips forward, somewhat incline back, and kick mightily, making contact between your lower shin or ball of your foot and the attacker's groin area.



Figure 8.9 Front Kick to Groin

Note:

Students, in order to have good skill of self-defense techniques, you need to spend more time to practice. Thus, be in pair and practice the above technique repeatedly by changing your roles. Do not forget safety measures.

2. Heel palm strike

This move can cause damage to the nose or throat. To execute, get in front of your attacker as much as is possible.

To perform:

- With your dominant hand, flex your wrist.
- Aim for either the attacker's nose, punching upward from the nostrils, or underneath the attacker's chin, punching upward at the throat.
- Make sure to start your strike. Pulling your arm back quickly will help thrust the attacker's head up and back.
- This will cause your attacker to stagger backward, allowing you to escape their grasp.



Figure 8.10 Heel Palm Strike

If your attacker is in close range and you are unable to get enough momentum to throw a strong punch or kick, use your elbows.

To perform:

- If you can, stabilize yourself with a strong core and legs to ensure a powerful blow.
- Bend your arm at the elbow, shift your weight forward, and strike your elbow into your attacker's neck, jawline, chin, or temple. These are all effective targets.
- This may cause your attacker to loosen their grip, allowing you to run.



Figure 8.11 Elbow Strike

8.3.4 Grappling

Grappling is a style of battling in nearquarters that as a rule happens on the ground. The common hooking definition is to hold, seize, or affix in a solid grasp. These focuses to an individual taking hold of another to stifle them.

In self-defense, as martial arts, grappling is the art of taking hold of your adversary at close range to pick up an advantage over them by locking them in a troublesome position or causing damage through the hold.

However, in self-defense, grappling is more than firmly holding on to your attacker.

Grappling ordinarily takes after a battling method, including throws, takedowns, and ground-fighting, which leads to the submission of the weaker opponent. The stronger rival is not fundamentally physically stronger but rather has a better understanding and use of grappling techniques to overcome the opponent.

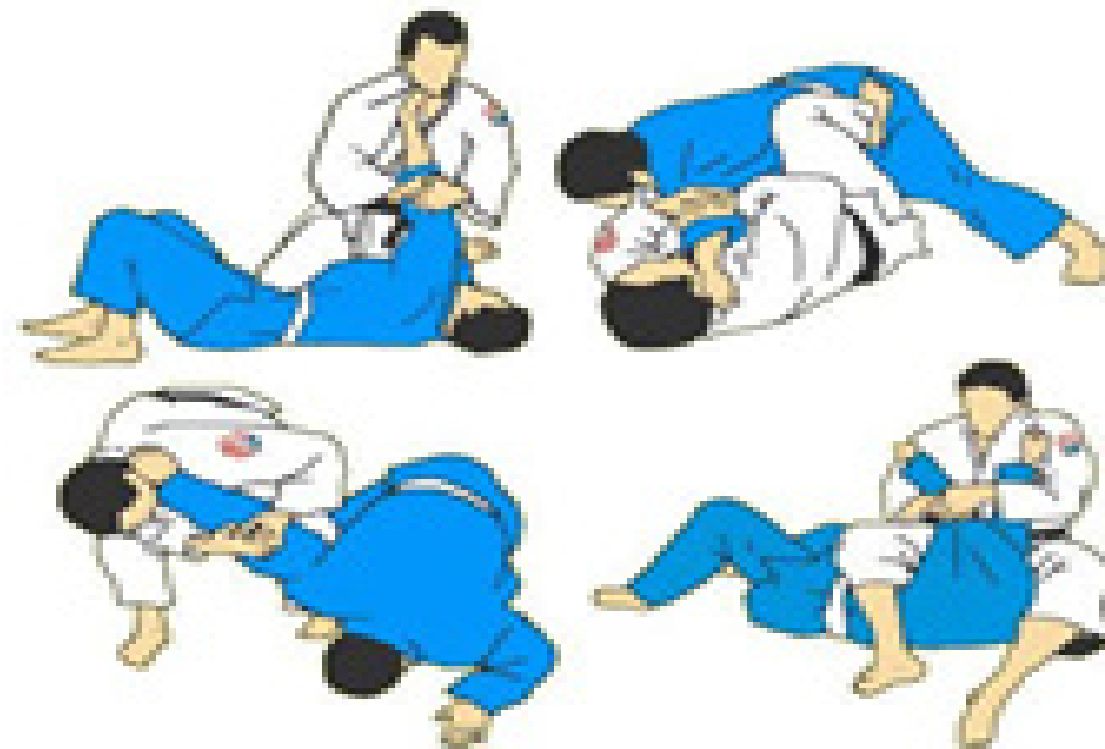

Figure 8.12 Grappling Techniques

Note:

Students, in order to have good skill of self-defense techniques, you need to spend more time to practice. Thus, be in pair and practice the above technique repeatedly by changing your roles. Do not forget safety measures.

Activity 8.1.4

- What is the importance of principles of self-defense?
- Can you mention some rules of self-defense?
- What are the skills of self-defense techniques?

Unit summary

Self-defense is defined as the right

to prevent suffering force through the use of a sufficient level of counteracting force or violence

The ability to protect oneself physically from harm is a basic human right that should be accessible to everyone, including children.

Participating in self-defense activities has many benefits like improve your physical and mental strength, It helps develop self-discipline,

In self-defense activity, safety measures play a vital role. Before doing any activities make sure that you are safe. Always start from simple one then you can proceed to the difficult one. Do not forget to wear proper sport wears,

which are vital for your safety.

- ☞ There are different Principles and rules of self-defense activities. You need to know all the principles and rules and apply while you are participating in self-defense activities.
- ☞ You can use techniques of self-defense if somebody may come and need to attack you.
- ☞ Escape from a 'bear hug attack', Escape with hands trapped and escape from side headlock are some of the techniques that you are going to use to escape from grabs.
- ☞ Groin kick, Heel palm strike, Elbow strike, and Grappling are some of the techniques that you are going to use when someone come to attack you.

Review questions

I. Write "true" if the statement is "correct" and writes "false" if the statement is incorrect (Give justification for your response)

1. Self-defense is the technique which is used by any person to defend him/her from any kinds of attack.
2. One of the objectives of learning self-defense is the attack you friends to show your skills.
3. Self-defense, grappling is simply firmly holding on to your attacker. Give your reason for your answer.

II. Choose the best answer from the given alternative

4. For which of the followings you are you giving special and more emphasis in self-defense?

A. Technic C. Principle

B. Safety D. Rules

5. The attacker is in close range and you are unable to get enough momentum to throw a strong punch or kick, which strike are you going to use?

A. Groin Kick C. Elbow strike

B. Heel palm strike D. All

6. What is self-defense? Why are you learning self-defense? Please reflect your idea to the class.

7. Students, do you think that self-defense is important to you? Please go to your community and discuss with the society on the importance of self-defense and come up with your reflection and present to the whole class.